

FusionServer 2488H V6 Server

Technical White Paper

Issue **01**
Date **2021-12-24**

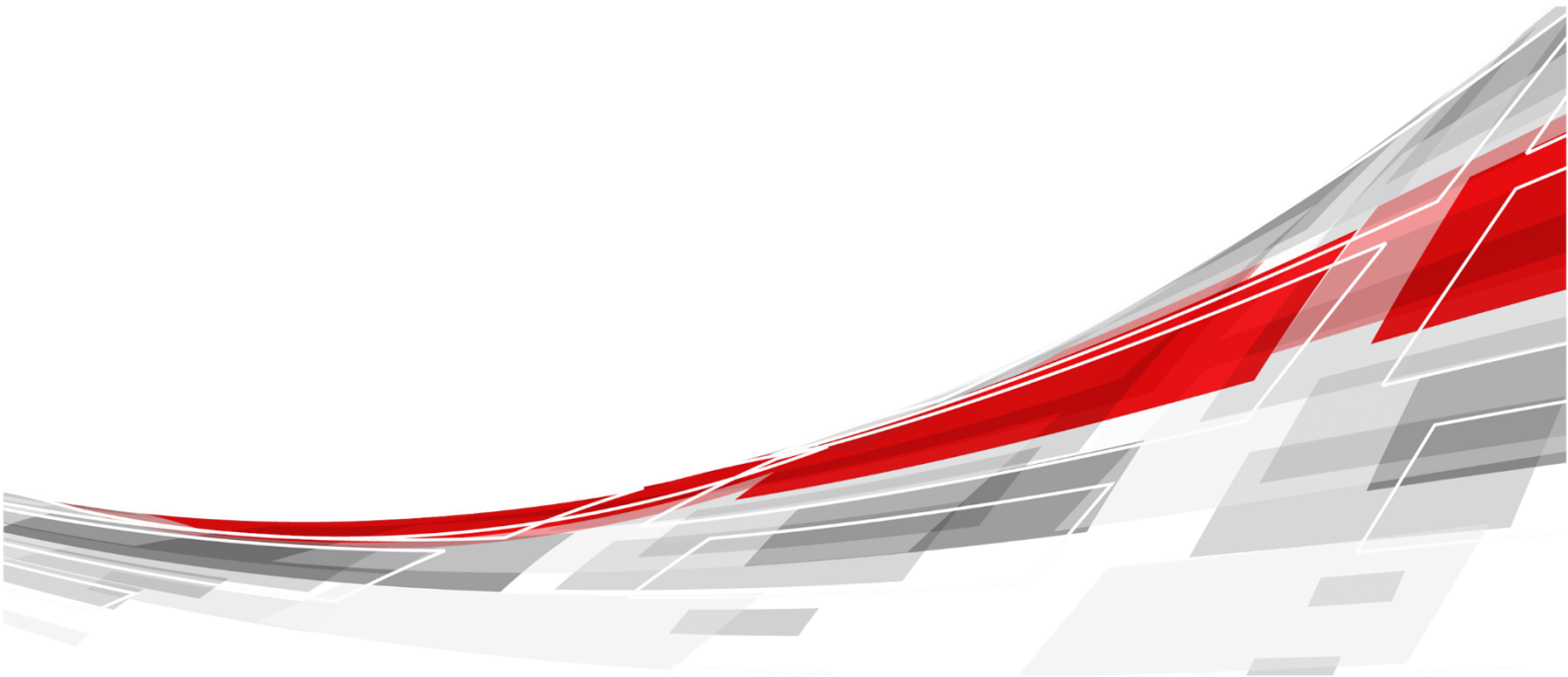

Copyrights © xFusion Digital Technologies Co., Ltd. 2021. All rights reserved.

No part of this document may be reproduced or transmitted in any form or by any means without prior written consent of xFusion Digital Technologies Co., Ltd.

Trademarks and Permissions

All other trademarks and trade names mentioned in this document are the property of their respective holders.

Notice

In this document, "xFusion" is used to refer to "xFusion Digital Technologies Co., Ltd." for concise description and easy understanding, which does not mean that "xFusion" may have any other meaning. Any "xFusion" mentioned or described hereof may not be understood as any meaning other than "xFusion Digital Technologies Co., Ltd.", and xFusion Digital Technology Co., Ltd. shall not bear any liability resulting from the use of "xFusion".

The purchased products, services and features are stipulated by the contract made between xFusion and the customer. All or part of the products, services and features described in this document may not be within the purchase scope or the usage scope. Unless otherwise specified in the contract, all statements, information, and recommendations in this document are provided "AS IS" without warranties, guarantees or representations of any kind, either express or implied.

The information in this document is subject to change without notice. Every effort has been made in the preparation of this document to ensure accuracy of the contents, but all statements, information, and recommendations in this document do not constitute a warranty of any kind, express or implied.

xFusion Digital Technologies Co., Ltd.

Address: 9th Floor, Building 1, Zensun Boya Square, Longzihu Wisdom Island
Zhengdong New District 450046
Zhengzhou, Henan Province
People's Republic of China

Website: <https://www.xfusion.com>

Contents

About This Document	v
1 Overview	7
2 Features	8
3 Physical Structure	11
4 Logical Structure	13
5 Hardware Description	14
5.1 Front Panel.....	14
5.1.1 Appearance	14
5.1.2 Indicators and Buttons	17
5.1.3 Ports	20
5.2 Rear Panel.....	24
5.2.1 Appearance	24
5.2.2 Indicators and Buttons	25
5.2.3 Ports	27
5.3 Processors	28
5.4 Memory	29
5.4.1 DDR4 Memory	29
5.4.1.1 Memory Identifier.....	29
5.4.1.2 Memory Subsystem Architecture.....	30
5.4.1.3 Memory Compatibility	32
5.4.1.4 Memory Installation Guidelines	33
5.4.1.5 Memory Installation Positions	34
5.4.1.6 Memory Protection Technologies	36
5.4.2 PMem.....	37
5.4.2.1 Memory Identifier.....	37
5.4.2.2 Memory Subsystem Architecture.....	37
5.4.2.3 Memory Compatibility	39
5.4.2.4 Memory Installation Guidelines	40
5.4.2.5 Memory Installation Positions	41
5.4.2.6 Memory Protection Technologies	44
5.5 Storage	45

5.5.1 Drive Configurations	45
5.5.2 Drive Numbering	51
5.5.3 Drive Indicators	56
5.5.4 RAID Controller Card	58
5.6 Network	58
5.6.1 OCP 3.0 Network Adapter	58
5.7 I/O Expansion	58
5.7.1 PCIe Cards	58
5.7.2 PCIe Slots	59
5.7.3 PCIe Slot Description	62
5.8 PSUs	63
5.9 Fan Modules	64
5.10 LCD	65
5.11 Boards	68
5.11.1 Mainboard	68
5.11.2 Drive Backplane	70
5.11.3 PSU Backplane	73
6 Product Specifications	74
6.1 Technical Specifications	74
6.2 Environmental Specifications	77
6.3 Physical Specifications	79
7 Software and Hardware Compatibility	81
8 Safety Instructions	82
8.1 Security	82
8.2 Maintenance and Warranty	85
9 System Management	86
A Appendix	88
B Glossary	98
C Acronyms and Abbreviations	101

About This Document

Overview





This document describes the FusionServer 2488H V6 rack server in terms of features, structure, specifications, and component hardware and software compatibility.

Intended Audience

This document is intended for pre-sales engineers.

Symbol Conventions

The symbols that may be found in this document are defined as follows.

Symbol	Description
 DANGER	Indicates a hazard with a high level of risk which, if not avoided, will result in death or serious injury.
 WARNING	Indicates a hazard with a medium level of risk which, if not avoided, could result in death or serious injury.
 CAUTION	Indicates a hazard with a low level of risk which, if not avoided, could result in minor or moderate injury.
 NOTICE	Indicates a potentially hazardous situation which, if not avoided, could result in equipment damage, data loss, performance deterioration, or unanticipated results. NOTICE is used to address practices not related to personal injury.
 NOTE	Supplements the important information in the main text. NOTE is used to address information not related to personal injury, equipment damage, and environment deterioration.

Change History

Issue	Date	Description
01	2021-12-24	This issue is the first official release.

1 Overview

FusionServer 2488H V6 (2488H V6) is a 2U 4-socket rack server developed for Internet data center (IDC), cloud computing, enterprise, and telecom service applications.

The 2488H V6 is ideal for applications such as databases, cloud computing, virtualization, in-memory computing, and deep learning.

The secure, compact 2488H V6 is a highly expandable server delivering high-performance computing, large storage capacity and low power consumption. It is easy to deploy and manage and supports virtualization.

 **NOTE**

For details about the 2488H V6 nameplate information, see A.3 Nameplate.

Figure 1-1 Physical structure of a 2488H V6 with 8 x 2.5" drives (example)



2 Features

Performance and Scalability

- Powered by the third-generation Intel® Xeon® Scalable Cooper Lake processors, the server provides up to 28 physical cores, 3.9 GHz frequency, a 38.5 MB L3 cache, and six 10.4 GT/s UPI links between the processors, which deliver supreme processing performance.
 - It supports four processors with 112 cores and 224 threads to maximize the concurrent execution of multithreaded applications.
 - The layered architecture of the processor cache is optimized. The L2 cache capacity is increased to process memory data directly, which greatly improves the memory access performance. Each core can exclusively use 1 MB of L2 cache, reducing the load on L3 cache. A single processor can share a maximum of 38.5 MB L3 cache.
 - Intel Turbo Boost Technology 2.0 allows processor cores to run faster than the frequency specified in the Thermal Design Power (TDP) configuration if they are operating below power, current, and temperature specification limits.
 - Intel Hyper-Threading Technology enables each processor core to run up to two threads, improving parallel computation capability.
 - The hardware-assisted Intel® Virtualization Technology (Intel® VT) allows operating system (OS) to better use hardware to address virtualization workloads.
 - Intel Deep Learning Boost (Intel DL Boost) works with the latest bfloat16 instruction set and Vector Neural Network Instructions (VNNI) to accelerate AI training and inference performance of the CPU.
 - With Intel® Advanced Vector Extensions 512 (AVX-512), applications can pack 32 double-precision and 64 single-precision floating-point operations per second in a clock cycle within the 512-bit vectors, as well as eight 64-bit and sixteen 32-bit integers, with up to two 512-bit fused multiply-add (FMA) units. Compared with Intel® Advanced Vector Extensions 2.0 (Intel® AVX2), Intel® AVX-512 doubles the width and number of data registers and the width of FMA units.
- The server supports a maximum of 48 DDR4 ECC 3200 MT/s DIMMs. The DDR4 ECC DIMMs support registered DIMMs (RDIMM) and load-reduced DIMMs (LRDIMMs), which provide high speed and availability.
- The server supports a maximum of 24 Intel® Optane™ Persistent Memory Module 200 series (PMem modules for short). When the DDR4 memory modules are used together, the server supports a maximum of 18 TB memory capacity (calculated based on a maximum of 256 GB capacity per DDR4 memory module and a maximum of 512 GB capacity per PMem module).

- Flexible drive configurations meet a variety of business requirements and ensure high elasticity and scalability of storage resources.
- The use of all solid-state drives (SSDs) is supported. An SSD supports up to 100 times more I/O operations per second (IOPS) than a typical hard disk drive (HDD). The use of all SSDs provides higher I/O performance than the use of all HDDs or a combination of HDDs and SSDs.
- The use of 12 Gbit/s SCSI (SAS) serial connection for internal storage provides 2x data transmission rate than the use of 6 Gbit/s SAS connection, maximizing the performance of I/O-intensive applications.
- With Intel integrated I/O, the third-generation Intel® Xeon® Scalable processors integrate the PCIe 3.0 controller to shorten I/O latency and improve overall system performance.
- The server supports a maximum of 11 PCIe 3.0 expansion slots, including one FlexIO card slot dedicated for the OCP 3.0 network adapter.
- The server supports one FlexIO card (applicable only to the OCP 3.0 network adapter) with flexible configuration of GE/10GE/25GE/100GE network adapters, which are hot swappable and support network controller sideband interface (NC-SI), HTTPS boot, preboot execution environment (PXE), and Wake on LAN (WoL).

Availability and Serviceability

- Carrier-class components with process expertise ensure high system reliability and availability.
- The server supports hot-swappable SAS/SATA/NVMe drives. SAS/SATA drives support RAID 0, 1, 10, 5, 50, 6, and 60, depending on the RAID controller card used. It also uses a supercapacitor to protect the RAID cache data against power failures.
- SSDs offer better reliability than HDDs, prolonging system uptime.
- The server provides simplified O&M and efficient troubleshooting through the UID/HLY indicators on the front panel, fault diagnosis LED, touch LCD diagnosis panel, and iBMC web interface.
- The mounting ears provide iBMC direct connect management ports to support local iBMC O&M, improving O&M efficiency.
- A server provides two hot-swappable PSUs in 1+1 redundancy mode and six hot-swappable fan modules in N+1 redundancy mode, improving system availability.
- The built-in iBMC monitors system parameters in real time, triggers alarms, and performs recovery actions to minimize the system downtime.
- For details about the warranty policy, visit [Warranty](#).

Manageability and Security

- The built-in iBMC monitors server operating status and provides remote management.
- A password is required for accessing the BIOS, ensuring system boot and management security.
- The NC-SI feature allows a network port to serve as a management port and a service port. The NC-SI feature is disabled by default and can be enabled through the iBMC or BIOS.
- The integrated Unified Extensible Firmware Interface (UEFI) improves setup, configuration, and update efficiency and simplifies fault handling.
- Lockable server chassis panel ensures security of local data.
- Chassis cover opening detection is supported to enhance security.

- Intel Execute Disable Bit (EDB) function prevents certain types of malicious buffer overflow attacks when working with a supported OS.
- The Intel Converged Boot Guard & Trusted Execution Technology (Intel CBnT) prevents malicious software attacks based on hardware, prevents the firmware from being maliciously modified, and prevents the execution of unauthorized boot blocks. It also allows applications to run in their own independent space without being affected by other software running in the system, thereby enhancing security.
- The trusted platform module (TPM) and trusted cryptography module (TCM) provide advanced encryption functions, such as digital signatures and remote authentication.
- The secure boot based on the BMC chip RoT implements level-by-level firmware verification and builds a secure boot chain, ensuring system security.
- The following requirements in NIST SP 800-147B are met:
 - The BIOS firmware digital signature update mechanism is supported. During the upgrade, the digital signature is verified to prevent unauthorized BIOS firmware upgrade.
 - The flash security protection mechanism is supported to prevent unauthorized modification of the flash memory in the OS.

NOTE

The service port with NC-SI enabled supports the following configuration:

- Configuring any port on the OCP 3.0 network adapter or other network adapters that support the NC-SI feature as the service port with NC-SI enabled.
- Enabling, disabling, and setting a virtual local area network (VLAN) ID for this port. The VLAN ID is 0 and disabled by default.
- Configuring IPv4 addresses (IPv4 address, subnet mask, and gateway) and IPv6 addresses (IPv6 address, prefix length, and gateway) for this port.

Energy Efficiency

- The server supports 80 Plus Platinum/Titanium PSUs of different energy efficiency levels. The PSU efficiency reaches 96% at 50% load.
- Efficient voltage regulator-down (VRD) power supplies for boards minimize the energy loss from DC/DC power conversion.
- Area-based, Proportional-Integral-Derivative (PID) intelligent fan speed adjustment and intelligent CPU frequency scaling optimize heat dissipation and reduce overall system power consumption.
- The improved thermal design with energy-efficient fans ensures optimal heat dissipation and reduces system power consumption.
- The server is protected with power capping and power control measures.
- Staggered spin-up of drives reduces the server boot power consumption.
- Intel Intelligent Power Capability allows the processor logic unit to be powered on or off based on requirements.
- The low-voltage third-generation Intel® Xeon® Scalable Cooper Lake processors consume less energy, ideally suited for data centers and telecommunications environments constrained by power and thermal limitations.
- SSDs consume 80% less power than HDDs.

3 Physical Structure

Figure 3-1 Physical structure of a server with 8 x 2.5" drives (example)

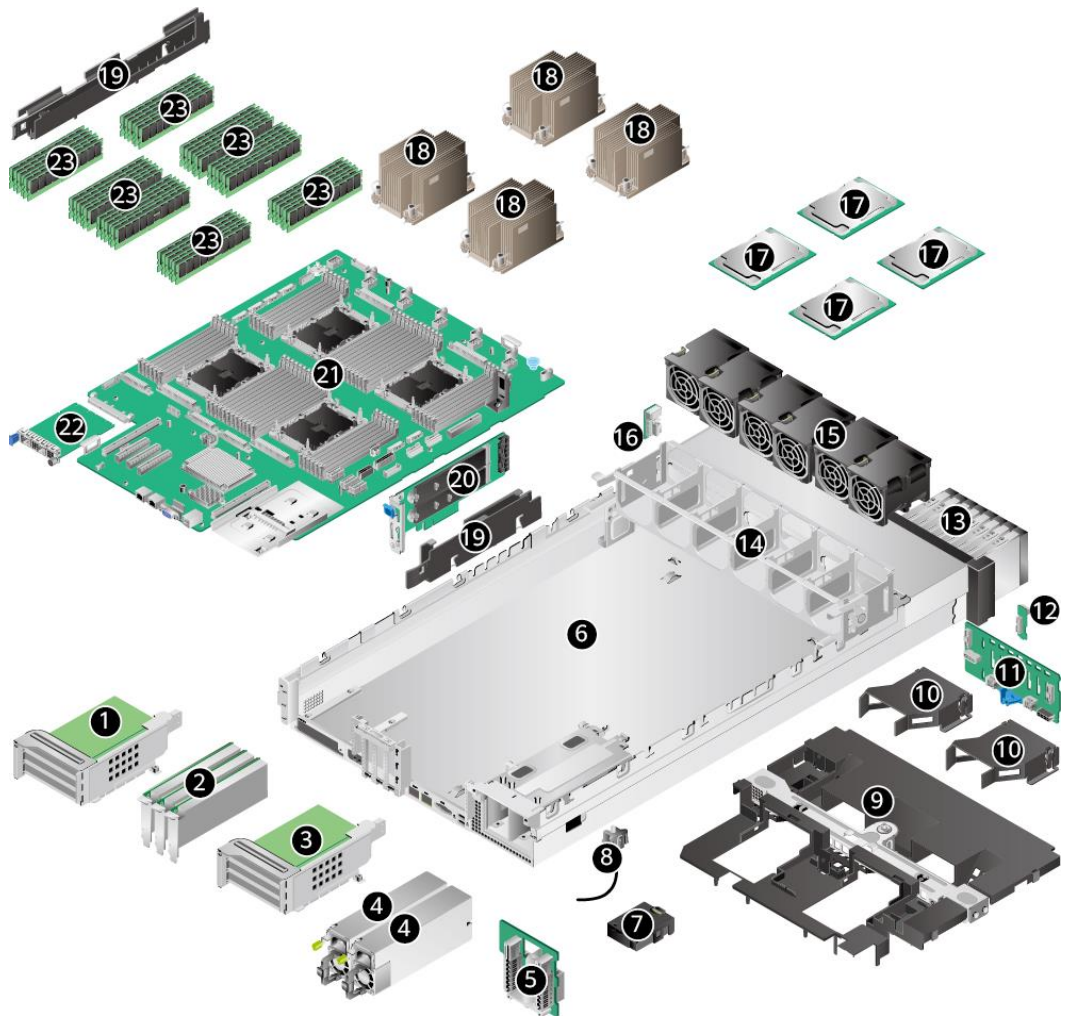

1	PCIe riser module 1	2	PCIe card
3	PCIe riser module 2	4	Power supply unit (PSU)

5	PSU backplane	6	Chassis
7	Supercapacitor ^a	8	Intrusion sensor
9	Primary air duct	10	Secondary air ducts ^b
11	Drive backplane	12	Left mounting ear plate
13	Drive	14	Fan module bracket
15	Fan module	16	Right mounting ear plate
17	Processor	18	Processor heat sink
19	Cable organizer	20	M.2 SSD ^c
21	Mainboard	22	OCP 3.0 Network Adapters
23	DIMM	-	-
<p>a: The server supports only PCIe RAID controller cards, which can be configured with a supercapacitor. For details about the slots for installing PCIe RAID controller cards, see 5.5.1 Drive Configurations .</p> <p>b: Secondary air ducts are not required when full-length PCIe cards are configured.</p> <p>c: If an M.2 SSD adapter card is configured, two M.2 SSDs can be configured in slot 10. If an Avago SAS3004iMR RAID controller card is configured, two M.2 FRUs can be configured in slot 1. For details, see 5.5.1 Drive Configurations .</p>			

4 Logical Structure

Figure 4-1 2488H V6 logical structure

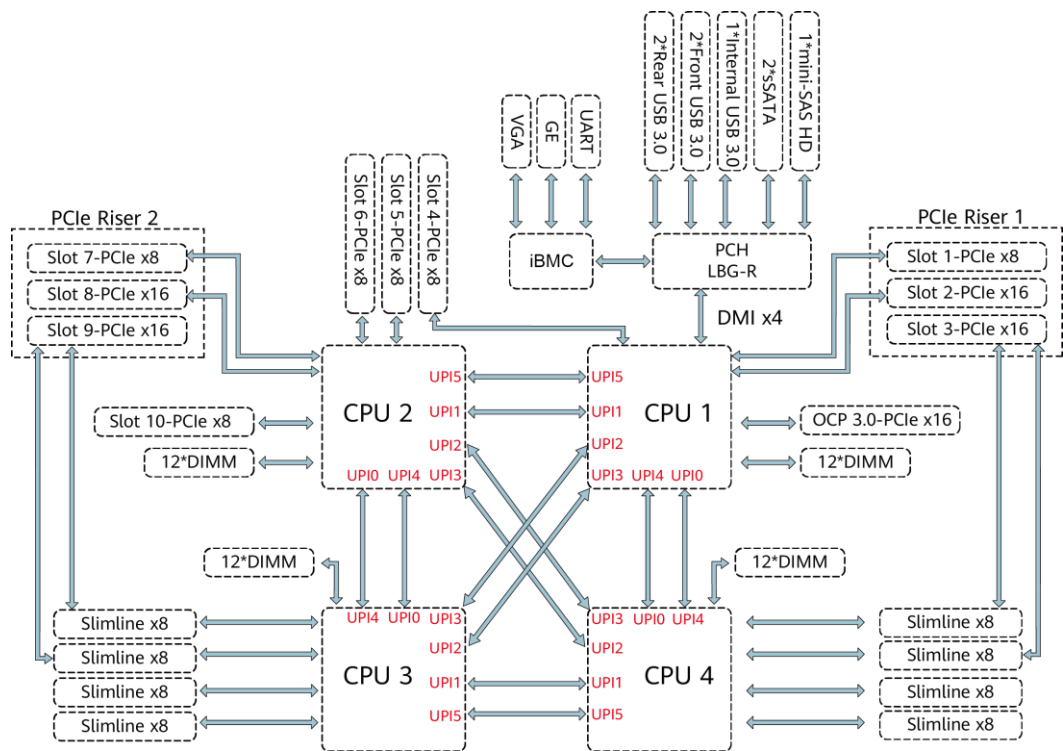

- The server supports two or four third-generation Intel® Xeon® Scalable processors.
- The server supports up to 48 memory modules.
- The CPUs (processors) interconnect with each other through six UPI links at a speed of up to 10.4 GT/s.
- The server supports a maximum of 11 PCIe 3.0 expansion slots, including one slot dedicated for the OCP 3.0 network adapter.
- The LBG-R Platform Controller Hub (PCH) is integrated on the mainboard to support five USB 3.0 ports and two SATA 3.0 ports.
- The BMC management chip integrated on the mainboard supports a video graphic array (VGA) port, a management network port, and a serial port.

5 Hardware Description

- 5.1 Front Panel
- 5.2 Rear Panel
- 5.3 Processors
- 5.4 Memory
- 5.5 Storage
- 5.6 Network
- 5.7 I/O Expansion
- 5.8 PSUs
- 5.9 Fan Modules
- 5.10 LCD
- 5.11 Boards

5.1 Front Panel

5.1.1 Appearance

- 8 x 2.5" drive pass-through configuration (8 x SAS/SATA)

Figure 5-1 Front view

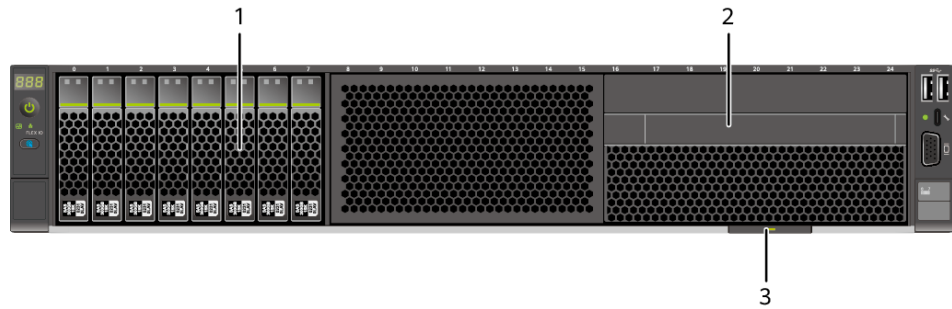

1	SAS/SATA drive	2	(Optional) Built-in DVD drive (or LCD module)
3	Slide-out label plate (with an SN label)	-	-

- 12 x 2.5" drive pass-through configuration (4 x SAS/SATA + 8 x NVMe)

Figure 5-2 Front view

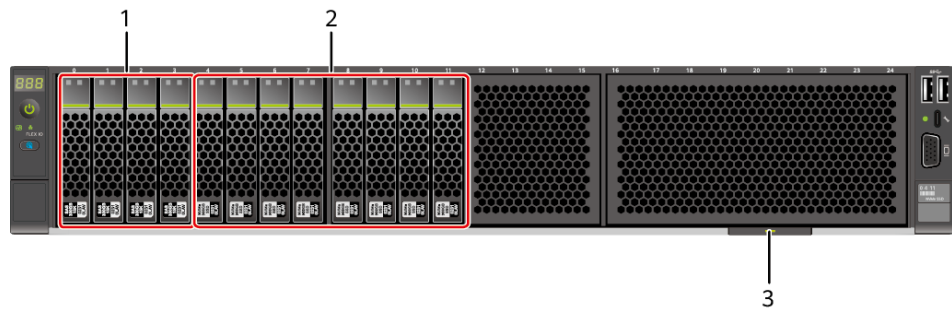

1	SAS/SATA drive	2	NVMe SSDs
3	Slide-out label plate (with an SN label)	-	-

- 20 x 2.5" drive pass-through configuration (4 x SAS/SATA + 16 x NVMe)

Figure 5-3 Front view

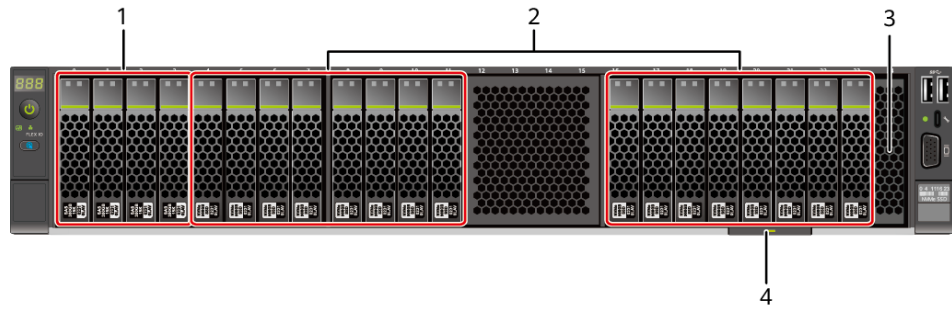

1	SAS/SATA drive	2	NVMe SSDs
3	Filler panel in drive slot NOTE The slot cannot hold drives.	4	Slide-out label plate (with an SN label)

- 24 x 2.5" drive pass-through configuration (24 x SAS/SATA)

Figure 5-4 Front view



1	SAS/SATA drive	2	Filler panel in drive slot NOTE The slot cannot hold drives.
3	Slide-out label plate (with an SN label)	-	-

- 25 x 2.5" drive EXP configuration (25 x SAS/SATA)

Figure 5-5 Front view



1	SAS/SATA drive	2	Slide-out label plate (with an SN label)
---	----------------	---	--

5.1.2 Indicators and Buttons

- 8 x 2.5" drive pass-through configuration (8 x SAS/SATA)

Figure 5-6 Indicators and buttons on the front panel

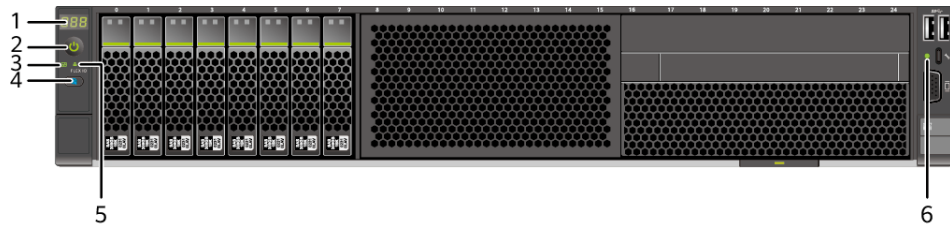

1	Fault diagnosis LED	2	Power button/indicator
3	Health status indicator	4	UID button/indicator
5	FlexIO card presence indicator	6	iBMC direct connect management port indicator

- 12 x 2.5" drive pass-through configuration (4 x SAS/SATA + 8 x NVMe)

Figure 5-7 Indicators and buttons on the front panel

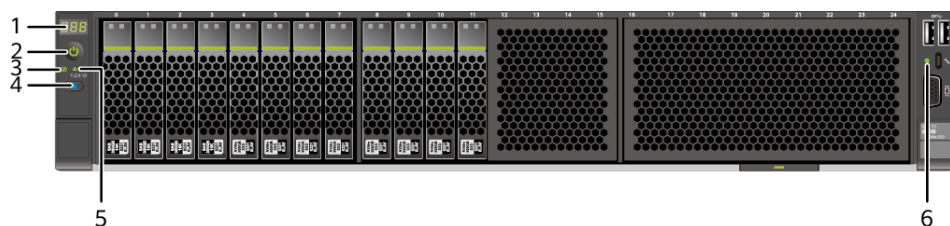

1	Fault diagnosis LED	2	Power button/indicator
3	Health status indicator	4	UID button/indicator
5	FlexIO card presence indicator	6	iBMC direct connect management port indicator

- 20 x 2.5" drive pass-through configuration (4 x SAS/SATA + 16 x NVMe)

Figure 5-8 Indicators and buttons on the front panel



1	Fault diagnosis LED	2	Power button/indicator
3	Health status indicator	4	UID button/indicator
5	FlexIO card presence indicator	6	iBMC direct connect management port indicator

- 24 x 2.5" drive pass-through configuration (24 x SAS/SATA)

Figure 5-9 Indicators and buttons on the front panel

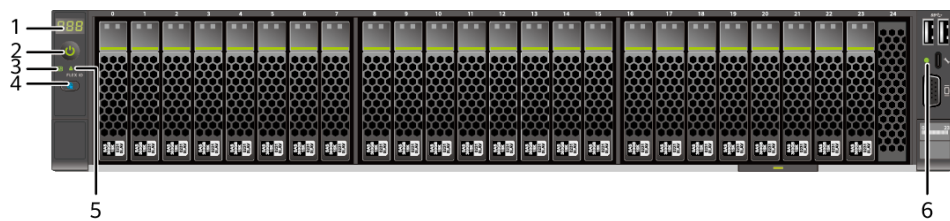

1	Fault diagnosis LED	2	Power button/indicator
3	Health status indicator	4	UID button/indicator
5	FlexIO card presence indicator	6	iBMC direct connect management port indicator

- 25 x 2.5" drive EXP configuration (25 x SAS/SATA)

Figure 5-10 Indicators and buttons on the front panel

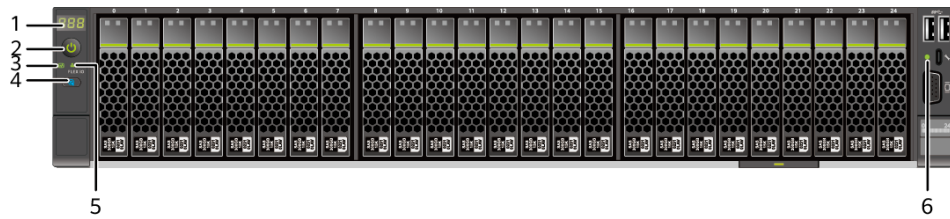





1	Fault diagnosis LED	2	Power button/indicator
3	Health status indicator	4	UID button/indicator
5	FlexIO card presence indicator	6	iBMC direct connect management port indicator

Indicator and Button Descriptions

Table 5-1 Description of indicators and buttons on the front panel

Silkscreen	Indicator and Button	Description
888	Fault diagnosis LED	<ul style="list-style-type: none"> ---: The device is operating properly. Error code: A component is faulty. For details about error codes, see the <i>FusionServer Rack Server iBMC Alarm Handling</i> .
⏻	Power button/indicator	Power indicator: <ul style="list-style-type: none"> Off: The device is not powered on. Steady green: The device is powered on. Blinking yellow: The iBMC is starting. The power button is locked and cannot be pressed. The iBMC is started in about 1 minute, and then the power indicator is steady yellow. Steady yellow: The device is standby. Power button: <ul style="list-style-type: none"> When the device is powered on, you can press this button to gracefully shut down the OS. NOTE For different OSs, you may need to shut down the OS as prompted. <ul style="list-style-type: none"> When the device is powered on, you can hold down this button for 6 seconds to forcibly power off the device. When the power indicator is steady yellow, you can press this button to power on the device.

Silkscreen	Indicator and Button	Description
	Health status indicator	<ul style="list-style-type: none"> • Off: The device is powered off or is faulty. • Blinking red at 1 Hz: A major alarm has been generated on the system. • Blinking red at 5 Hz: A critical alarm has been generated on the system. • Steady green: The device is operating properly.
	UID button/indicator	<p>The UID button/indicator helps identify and locate a device.</p> <p>UID indicator:</p> <ul style="list-style-type: none"> • Off: The device is not being located. • Blinking or steady blue: The device is being located. <p>UID button:</p> <ul style="list-style-type: none"> • You can control the UID indicator status by pressing the UID button or using the iBMC. • You can press this button to turn on or off the UID indicator. • You can press and hold down this button for 4 to 6 seconds to reset the iBMC.
	FlexIO card presence indicator	<ul style="list-style-type: none"> • Off: The FlexIO card is not detected. • Blinking green at 0.5 Hz: The FlexIO card is detected but is not powered on. • Blinking green at 2 Hz: The FlexIO card is detected and has just been inserted. • Steady green: The FlexIO card is detected and the power supply is normal.
	iBMC direct connect management port indicator	<p>Indicates the status when the iBMC direct connect management port connects to a terminal (local PC or Android mobile phone):</p> <ul style="list-style-type: none"> • Off: No terminal is connected. • Blinking green at short intervals for 3 seconds and then off: The port is disabled. • Steady green: The terminal is connected.

5.1.3 Ports

- 8 x 2.5" drive pass-through configuration (8 x SAS/SATA)

Figure 5-11 Ports on the front panel



1	USB 3.0 ports	2	iBMC direct connect management port
3	VGA port	-	-

- 12 x 2.5" drive pass-through configuration (4 x SAS/SATA + 8 x NVMe)

Figure 5-12 Ports on the front panel

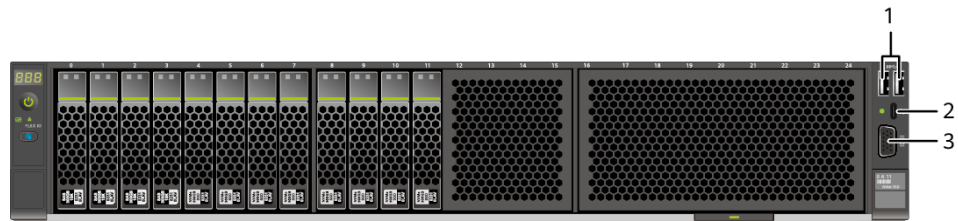

1	USB 3.0 port	2	iBMC direct connect management port
3	VGA port	-	-

- 20 x 2.5" drive pass-through configuration (4 x SAS/SATA + 16 x NVMe)

Figure 5-13 Ports on the front panel

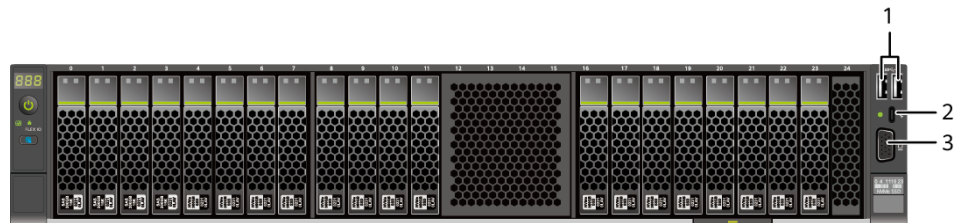

1	USB 3.0 port	2	iBMC direct connect management port
3	VGA port	-	-

- 24 x 2.5" drive pass-through configuration (24 x SAS/SATA)

Figure 5-14 Ports on the front panel

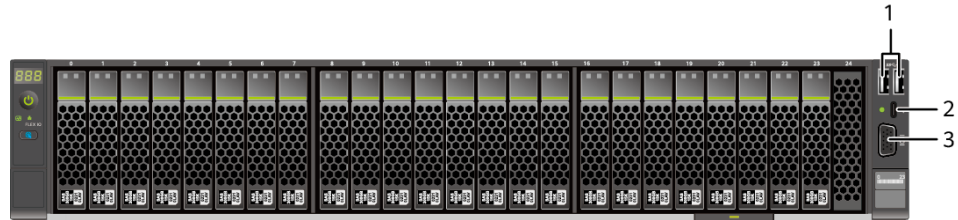

1	USB 3.0 port	2	iBMC direct connect management port
3	VGA port	-	-

- 25 x 2.5" drive EXP configuration (25 x SAS/SATA)

Figure 5-15 Ports on the front panel

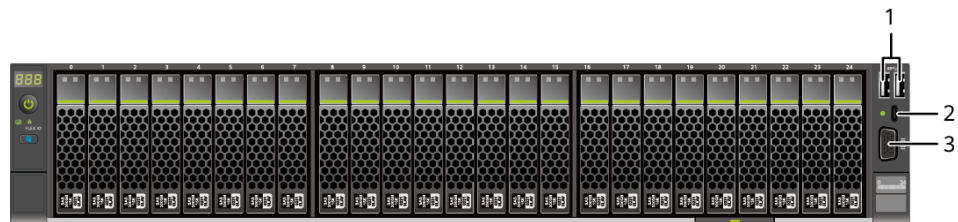

1	USB 3.0 port	2	iBMC direct connect management port
3	VGA port	-	-

Port Description

Table 5-2 Ports on the front panel

Port	Type	Quantity	Description
VGA port	DB15	1	Used to connect a display terminal, such as a monitor or KVM.
iBMC direct connect management	USB Type-C NOTE The USB 2.0	1	Used to connect to a local PC or mobile phone through a USB Type-C cable to monitor and

Port	Type	Quantity	Description
port	protocol is supported.		manage the system. NOTE Only local PCs running Windows 10 and mobile phones running Android are supported. <ul style="list-style-type: none"> • To log in to the iBMC from the local PC, enter https://IP address of the iBMC management network port in the address box of the browser on the local PC. • When accessing the iBMC through a mobile phone, you need to use the mobile application SmartServer to access the iBMC. For details, see the <i>Server SmartServer User Guide</i> .
USB 3.0 port	USB 3.0	2	Used to connect to a USB 3.0 device. NOTICE <ul style="list-style-type: none"> • Before connecting an external USB device, ensure that the USB device functions properly. Otherwise, it may adversely impact the server. • The USB 3.0 port can be used to supply power to low-power peripherals. However, the USB 3.0 port must comply with the USB specifications. To run advanced peripherals, such as external CD/DVD drives, an external power supply is required.

5.2 Rear Panel

5.2.1 Appearance

Figure 5-16 Rear view

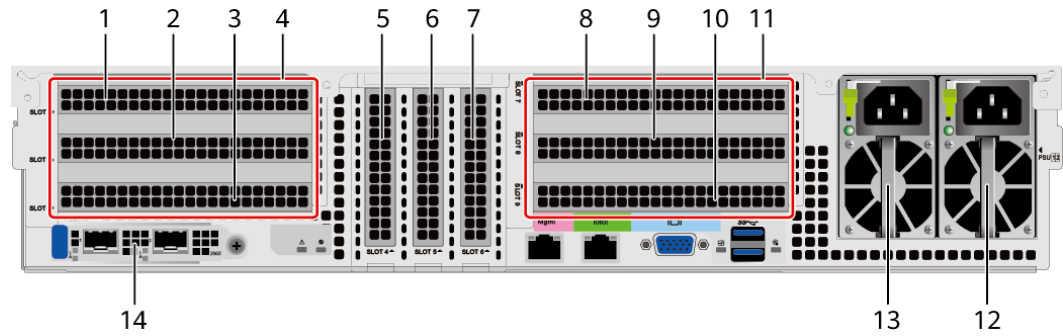

1	PCIe Slot1	2	PCIe Slot2
3	PCIe Slot3	4	PCIe riser module 1
5	PCIe Slot4	6	PCIe Slot5
7	PCIe Slot6	8	PCIe Slot7
9	PCIe Slot8	10	PCIe Slot9
11	PCIe riser module 2	12	Power supply 2
13	PSU 1	14	(Optional) FlexIO card NOTE The FlexIO card slot supports only OCP 3.0 network adapters.

NOTE

- For details about the OCP 3.0 network adapter, see 5.6.1 OCP 3.0 Network Adapter .
- The figure is for reference only. The actual configuration may vary.

5.2.2 Indicators and Buttons

Indicator Positions

Figure 5-17 Indicators on the rear panel

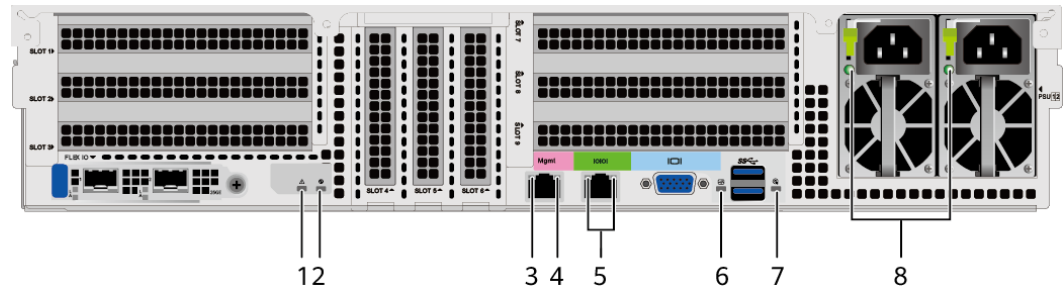

1	FlexIO card status indicator	2	FlexIO card power indicator
3	Data transmission status indicator for the management network port	4	Connection status indicator for the management network port
5	Serial port indicators NOTE Reserved and unavailable currently.	6	Health status indicator
7	UID indicator	8	PSU indicators

Indicator Description

Table 5-3 Indicators on the rear panel

Silkscreen	Indicator	Description
⚠	FlexIO card status indicator	FlexIO cards support only orderly hot swap. For details, see Table 5-4.
⌚	FlexIO card power indicator	FlexIO cards support only orderly hot swap. For details, see Table 5-4.
-	Data transmission status indicator for the management network port	<ul style="list-style-type: none"> Off: No data is being transmitted. Blinking yellow: Data is being transmitted.
-	Connection status indicator for the management network port	<ul style="list-style-type: none"> Off: The network port is not connected. Steady green: The network port is connected properly.



Silkscreen	Indicator	Description
	Health status indicator	<ul style="list-style-type: none"> • Off: The device is powered off or is faulty. • Blinking red at 1 Hz: A major alarm has been generated on the system. • Blinking red at 5 Hz: A critical alarm has been generated on the system. • Steady green: The device is operating properly.
	UID indicator	<p>The UID indicator helps identify and locate a device.</p> <ul style="list-style-type: none"> • Off: The device is not being located. • Blinking or steady blue: The device is being located. <p>NOTE You can control the UID indicator status by pressing the UID button or using the iBMC.</p>
-	PSU indicator	<ul style="list-style-type: none"> • Off: No power is supplied. • Blinking green at 1 Hz: <ul style="list-style-type: none"> – The input is normal, and the server is standby. – The input is overvoltage or undervoltage. – The PSU is in deep hibernation mode. • Blinking green at 4 Hz: The firmware is being upgraded online. • Steady green: The power input and output are normal. • Steady orange: The input is normal but there is no output. <p>NOTE The possible causes of no power output are as follows:</p> <ul style="list-style-type: none"> • Power supply overtemperature protection • Power output overcurrent or short-circuit • Output overvoltage • Short-circuit protection • Device failure (excluding failure of all devices)

Table 5-4 FlexIO card power indicator and status indicator

FlexIO Card Power Indicator (Green)	FlexIO Card Status Indicator (Yellow)	Description
Off	Off	The FlexIO card is not detected.
Steady on	Off	The FlexIO card is detected and operating properly.
Steady on	Blinking at 2 Hz	The FlexIO card is being hot-swapped.
Off	Blinking at 0.5 Hz	The FlexIO card has completed the hot swap process and is removable.
Off	Steady on	The FlexIO card is faulty.

5.2.3 Ports

Port Positions

Figure 5-18 Ports on the rear panel

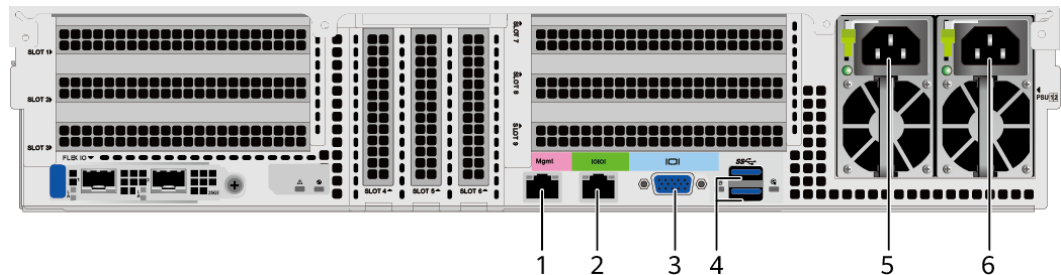

1	Management network port	2	Serial port
3	VGA port	4	USB 3.0 ports
5	Socket for PSU 1	6	Socket for PSU 2

Port Description

Table 5-5 Ports on the rear panel

Port	Type	Quantity	Description
Management network port	RJ45	1	iBMC management network port, which is used to manage the server. NOTE

Port	Type	Quantity	Description
			The management network port is a GE port that supports 100 Mbit/s and 1000 Mbit/s auto-negotiation.
Serial port	RJ45	1	Default operating system serial port used for debugging. You can also set it as the iBMC serial port by using the iBMC command. NOTE The port uses 3-wire serial communication interface, and the default baud rate is 115,200 bit/s.
VGA port	DB15	1	Used to connect a display terminal, such as a monitor or KVM.
USB 3.0 port	USB 3.0	2	Used to connect to a USB 3.0 device. NOTICE <ul style="list-style-type: none"> • Before connecting an external USB device, ensure that the USB device functions properly. Otherwise, it may adversely impact the server. • The USB 3.0 port can be used to supply power to low-power peripherals. However, the USB 3.0 port must comply with the USB specifications. To run advanced peripherals, such as external CD/DVD drives, an external power supply is required.
PSU socket	-	2	Used to connect to a power distribution unit (PDU) through a power cable. You can select the PSUs as required. NOTE When determining the PSUs, ensure that the rated power of the PSUs is greater than that of the server.

5.3 Processors

- The server supports two or four processors.
- If two processors are required, install them in sockets CPU1 and CPU2.
- Processors of the same model must be used in a server.
- Contact your local sales representative or see "Search Parts" in the [Compatibility Checker](#) to determine the components to be used.

Figure 5-19 Processor positions

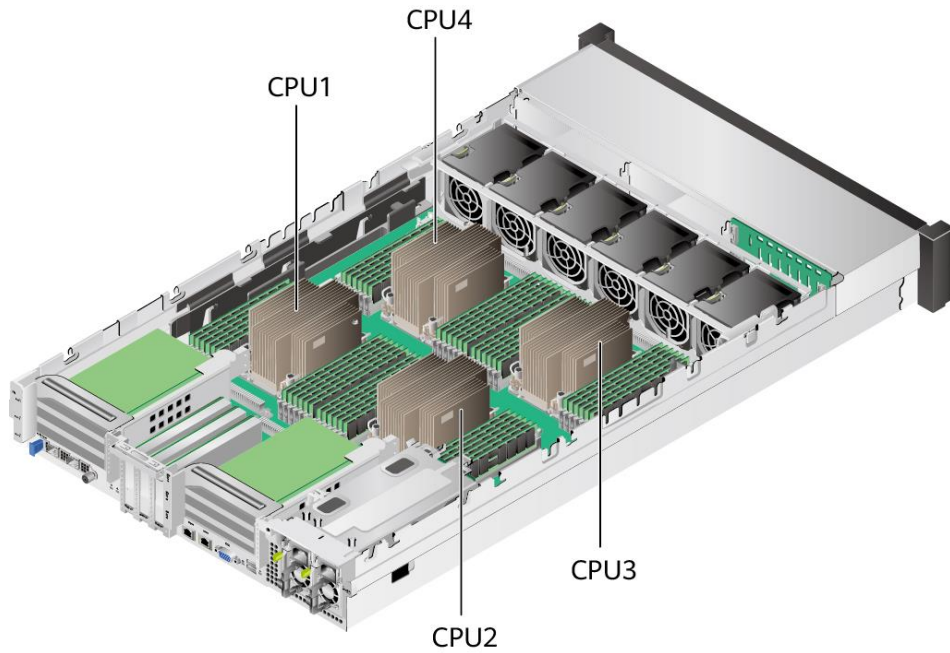

5.4 Memory

5.4.1 DDR4 Memory

5.4.1.1 Memory Identifier

You can determine the memory module properties based on the label attached to the memory module.

Figure 5-20 Memory identifier

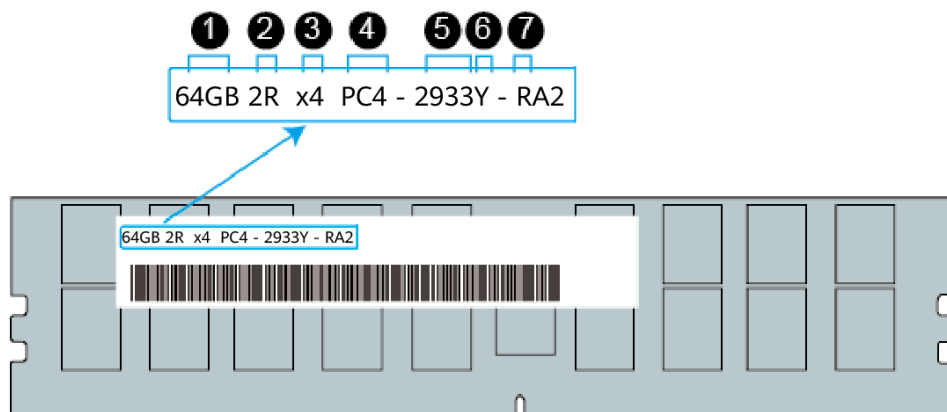

Callout	Description	Example
---------	-------------	---------

Callout	Description	Example
1	Capacity	<ul style="list-style-type: none"> • 16 GB • 32 GB • 64 GB • 128 GB
2	Number of ranks	<ul style="list-style-type: none"> • 1R: single-rank • 2R: dual-rank • 4R: quad-rank
3	Data width on the DRAM	<ul style="list-style-type: none"> • x4: 4-bit • x8: 8-bit
4	Type of the memory interface	<ul style="list-style-type: none"> • PC4: DDR4
5	Maximum memory speed	<ul style="list-style-type: none"> • 2933 MT/s • 3200 MT/s
6	Memory latency parameters (CL-tRCD-tRP)	<ul style="list-style-type: none"> • W = 20-20-20 • Y = 21-21-21 • AA = 22-22-22
7	DIMM type	<ul style="list-style-type: none"> • R = RDIMM • L = LRDIMM

5.4.1.2 Memory Subsystem Architecture

A server provides 48 memory slots. Each processor integrates six memory channels.

Install the memory modules in the primary memory channels first. If the primary memory channel is not populated, the memory modules in secondary memory channels cannot be used.

Table 5-6 Memory channels

CPU	Memory Channel	Memory Slot
CPU 1	A (primary)	DIMM000(A)
	A	DIMM001(G)
	B (primary)	DIMM010(B)
	B	DIMM011(H)
	C (primary)	DIMM020(C)
	C	DIMM021(I)
	D (primary)	DIMM030(D)
	D	DIMM031(J)
	E (primary)	DIMM040(E)

CPU	Memory Channel	Memory Slot
	E	DIMM041(K)
	F (primary)	DIMM050(F)
	F	DIMM051(L)
CPU 2	A (primary)	DIMM100(A)
	A	DIMM101(G)
	B (primary)	DIMM110(B)
	B	DIMM111(H)
	C (primary)	DIMM120(C)
	C	DIMM121(I)
	D (primary)	DIMM130(D)
	D	DIMM131(J)
	E (primary)	DIMM140(E)
	E	DIMM141(K)
	F (primary)	DIMM150(F)
	F	DIMM151(L)
CPU 3	A (primary)	DIMM200(A)
	A	DIMM201(G)
	B (primary)	DIMM210(B)
	B	DIMM211(H)
	C (primary)	DIMM220(C)
	C	DIMM221(I)
	D (primary)	DIMM230(D)
	D	DIMM231(J)
	E (primary)	DIMM240(E)
	E	DIMM241(K)
	F (primary)	DIMM250(F)
	F	DIMM251(L)
CPU 4	A (primary)	DIMM300(A)
	A	DIMM301(G)
	B (primary)	DIMM310(B)
	B	DIMM311(H)

CPU	Memory Channel	Memory Slot
	C (primary)	DIMM320(C)
	C	DIMM321(I)
	D (primary)	DIMM330(D)
	D	DIMM331(J)
	E (primary)	DIMM340(E)
	E	DIMM341(K)
	F (primary)	DIMM350(F)
	F	DIMM351(L)

5.4.1.3 Memory Compatibility

Observe the following rules when configuring DDR4 memory modules:

NOTICE

- A server must use DDR4 memory modules of the same part number (P/N code), and the memory speed is the minimum value of the following items:
 - Memory speed supported by a CPU
 - Maximum operating speed of a memory module
- The DDR4 DIMMs of different types (RDIMM and LRDIMM) and specifications (capacity, bit width, rank, and height) cannot be used together.
- Contact your local sales representative or see "Search Parts" in the [Compatibility Checker](#) to determine the components to be used.
- The memory can be used with the third-generation Intel® Xeon® Scalable Cooper Lake processors. The maximum memory capacity supported varies depending on the processor model:
 - H processors: 1.12 TB/socket
 - HL processors: 4.5 TB/socket
- Total memory capacity = Total capacity of all DDR4 memory modules

NOTICE

The total memory capacity cannot exceed the maximum memory capacity supported by the CPUs.

- For details about the capacity type of a single memory module, see "Search Parts" in the [Compatibility Checker](#).
- The maximum number of memory modules supported depends on the CPU type, memory type, and number of ranks.

 **NOTE**

Each RDIMM channel supports a maximum of 4 ranks and Each LRDIMM channel supports a maximum of 8 ranks. The number of memory modules supported by each channel varies depending on the number of ranks supported by each channel:

Number of memory modules supported by each channel ≤ Number of ranks supported by each memory channel/Number of ranks supported by each memory module

Table 5-7 DDR4 memory specifications

Parameter		Specifications			
Capacity per DDR4 memory module (GB)		16	32	64	128
Type		RDIMM	RDIMM	RDIMM	LRDIMM
Rated speed (MT/s)		3200	3200	3200	3200
Operating voltage (V)		1.2	1.2	1.2	1.2
Maximum number of DDR4 DIMMs in a server ^a		48	48	48	48
Maximum DDR4 memory capacity of the server (GB) ^b		768	1536	3072	6144
Actual rate (MT/s)	1DPC ^c	3200	3200	3200	3200
	2DPC	3200	3200	3200	3200
<ul style="list-style-type: none"> • a: The maximum number of DDR4 memory modules is based on four-processor configuration. The value is halved for a server with two processors. • b: The maximum DDR4 memory capacity varies depending on the CPU type. This table lists the maximum DDR4 memory capacity when the server is fully configured with memory modules. • c: DPC (DIMM per channel) indicates the number of memory modules per channel. • The information listed in this table is for reference only. For details, consult the local sales representative. 					

5.4.1.4 Memory Installation Guidelines

 **NOTE**

This section applies to a server fully configured with DDR4 memory modules. If PMem modules are used together, see 5.4.2.4 Memory Installation Guidelines.

Observe the following when configuring DDR4 memory modules:

- Install memory modules only when corresponding processors are installed.
- Do not install LRDIMMs and RDIMMs in the same server.
- Install filler memory modules in vacant slots.

Observe the following when configuring DDR4 memory modules in specific operating mode:

- Memory sparing mode

- Comply with the general installation guidelines.
- Each memory channel must have a valid online spare configuration.
- The channels can have different online spare configurations.
- Each populated channel must have a spare rank.
- Memory mirroring mode
 - Comply with the general installation guidelines.
 - Each processor supports two integrated memory controllers (IMCs), and each IMC has at least two channels (channels 1 and 2 or channels 1, 2, and 3) for installing memory modules. The installed memory modules must be identical in size and organization.
 - For a multi-processor configuration, each processor must have a valid memory mirroring configuration.
- Memory scrubbing mode
 - Comply with the general installation guidelines.

5.4.1.5 Memory Installation Positions

A server supports a maximum of 48 DDR4 memory modules. To maximize performance, balance the total memory capacity between the installed processors and to load the channels similarly whenever possible.

Observe the memory module installation rules when configuring memory modules. For details, see [Memory Configuration Assistant](#).

NOTICE

At least one DDR4 memory module must be installed in the primary memory channels corresponding to CPU 1.

Figure 5-21 Memory slots

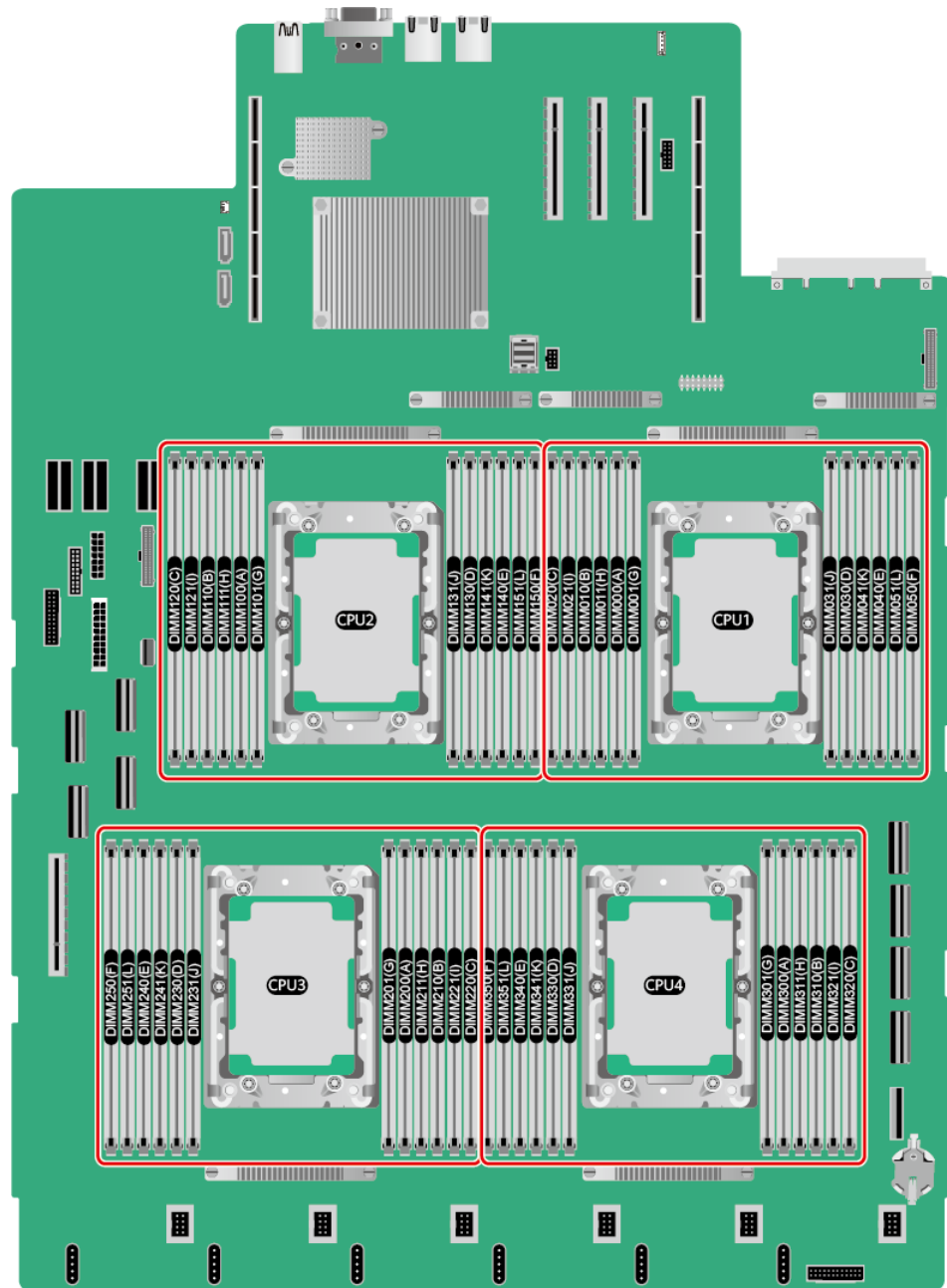

- Memory Multi Rank Sparing
- Post Package Repair (PPR)
- Write Data CRC Protection
- Adaptive Data Correction - Single Region (ADC-SR)
- Adaptive Double Device Data Correction - Multiple Region (ADDDC-MR, +1)

5.4.2 PMem

5.4.2.1 Memory Identifier

Figure 5-24 Memory identifier

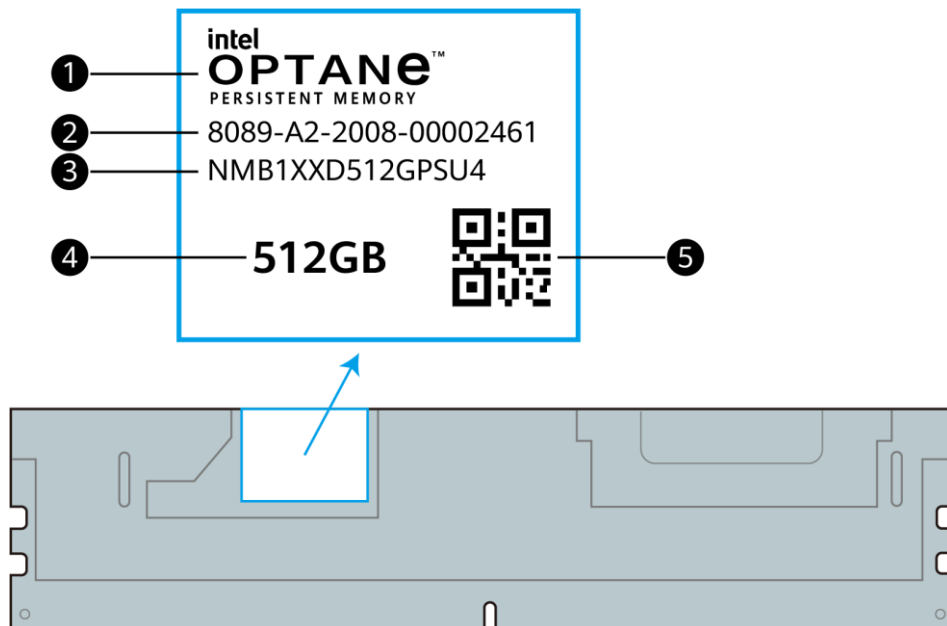

No.	Description	Example
1	Component	Intel Optane™ Persistent Memory
2	SN	8089-A2-2008-00002461
3	Model	NMB1XXD512GPSU4
4	Capacity (GB)	<ul style="list-style-type: none"> • 128 • 256 • 512
5	SN QR code	8089-A2-2008-00002461

5.4.2.2 Memory Subsystem Architecture

The server provides 48 memory slots. Each processor integrates six memory channels, and each memory channel supports only one PMem module.

The PMem modules must be used with the DDR4 memory modules, and the DDR4 memory module can be installed only in the memory slot of the primary memory channel.

Table 5-8 Memory channels

CPU	Memory Channel	Memory Slot
CPU 1	A (primary)	DIMM000(A)
	A	DIMM001(G)
	B (primary)	DIMM010(B)
	B	DIMM011(H)
	C (primary)	DIMM020(C)
	C	DIMM021(I)
	D (primary)	DIMM030(D)
	D	DIMM031(J)
	E (primary)	DIMM040(E)
	E	DIMM041(K)
	F (primary)	DIMM050(F)
	F	DIMM051(L)
CPU 2	A (primary)	DIMM100(A)
	A	DIMM101(G)
	B (primary)	DIMM110(B)
	B	DIMM111(H)
	C (primary)	DIMM120(C)
	C	DIMM121(I)
	D (primary)	DIMM130(D)
	D	DIMM131(J)
	E (primary)	DIMM140(E)
	E	DIMM141(K)
	F (primary)	DIMM150(F)
	F	DIMM151(L)
CPU 3	A (primary)	DIMM200(A)
	A	DIMM201(G)
	B (primary)	DIMM210(B)
	B	DIMM211(H)

CPU	Memory Channel	Memory Slot
	C (primary)	DIMM220(C)
	C	DIMM221(I)
	D (primary)	DIMM230(D)
	D	DIMM231(J)
	E (primary)	DIMM240(E)
	E	DIMM241(K)
	F (primary)	DIMM250(F)
	F	DIMM251(L)
CPU 4	A (primary)	DIMM300(A)
	A	DIMM301(G)
	B (primary)	DIMM310(B)
	B	DIMM311(H)
	C (primary)	DIMM320(C)
	C	DIMM321(I)
	D (primary)	DIMM330(D)
	D	DIMM331(J)
	E (primary)	DIMM340(E)
	E	DIMM341(K)
	F (primary)	DIMM350(F)
	F	DIMM351(L)

5.4.2.3 Memory Compatibility

Observe the following rules when configuring PMem modules:

NOTICE

- The PMem modules must be used with the DDR4 memory modules. For details, see *FusionServer PMem 200 User Guide*.
- Contact your local sales representative or see "Search Parts" in the [Compatibility Checker](#) to determine the components to be used.
- The memory must be used with the third-generation Intel® Xeon® Scalable Cooper Lake processors. The maximum memory capacity supported varies depending on the processor model:

- H processors: 1.12 TB/socket
- HL processors: 4.5 TB/socket
- The PMem module can work only in App Direct Mode (AD). The total supported memory capacity is calculated as follows:
 Total memory capacity = Total capacity of all PMem modules+ Total capacity of all DDR4 memory modules

NOTICE

The total memory capacity cannot exceed the maximum memory capacity supported by the CPUs.

- For details about the capacity type of a single memory module, see "Search Parts" in the [Compatibility Checker](#).

Table 5-9 PMem specifications

Parameter	Specifications		
Capacity per PMem module (GB)	128	256	512
Rated speed (MT/s)	3200	3200	3200
Operating voltage (V)	1.2	1.2	1.2
Maximum number of PMem modules in a server ^a	24	24	24
Maximum PMem capacity of the server (GB) ^b	3072	6144	12288
Actual rate (MT/s)	2666	2666	2666
<ul style="list-style-type: none"> • a: The maximum number of PMem modules is based on four-processor configuration. The value is halved for a server with two processors. • b: The maximum PMem capacity varies depending on the CPU type and PMem working mode. • The information listed in this table is for reference only. For details, consult the local sales representative. 			

5.4.2.4 Memory Installation Guidelines

- Observe the following when configuring PMem modules:
 - The DDR4 memory modules used with the PMem modules include RDIMMs and LRDIMMs.
 - The PMem modules used in a server must have the same part number (P/N code).
 - The DDR4 memory modules used with the PMem modules in a server must have the same part number (P/N code).
- Observe the following when configuring PMem modules in AD mode:

- On the same server, it is recommended that the ratio of the DDR4 memory capacity to the PMem capacity be 1:1 to 1:4.
- The mapping between the PMem modules and CPUs is as follows:
 - The PMem module needs to be supported by the H/HL CPUs of Cooper Lake.
 - Table 5-10 lists the maximum memory capacity supported by different CPUs.

Table 5-10 Maximum memory capacity supported by a CPU

CPU type	Maximum Memory Capacity Supported by a CPU (DDR4 and PMem Capacities)
Cooper Lake H series	1.12 TB (6 x 64 GB DDR4 + 6 x 128 GB PMem)
Cooper Lake HL series	4.5 TB (6 x 256 GB DDR4 + 6 x 512 GB PMem)
Note: For details about the configurable memory capacity, see "Search Parts" in the Compatibility Checker .	

5.4.2.5 Memory Installation Positions

A server supports a maximum of 24 PMem modules. The PMem modules must be used with the DDR4 memory modules.

Observe the memory module installation rules when configuring memory modules. For details, see [Memory Configuration Assistant](#).

Figure 5-25 Memory slots

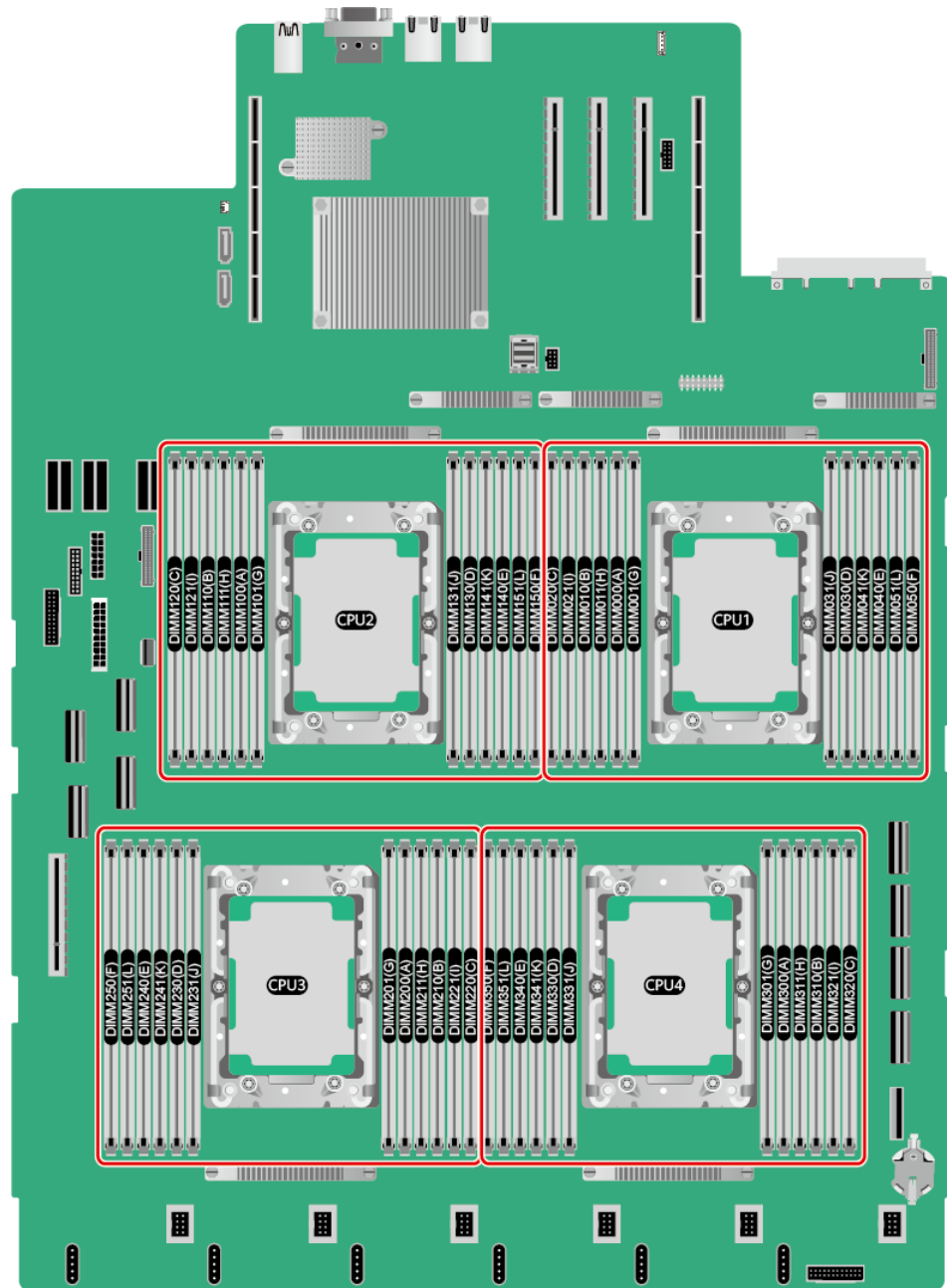

Figure 5-26 PMem installation guidelines (2 processors)

CPU	Channel	DIMM Slot	Installation Guideline (●: DDR4 ○: PMem)		
			AD	6+6	
CPU1	IMC0	A	DIMM000(A)	●	○
			DIMM001(G)	○	○
		B	DIMM010(B)	●	○
			DIMM011(H)	○	○
		C	DIMM020(C)	●	○
			DIMM021(I)	○	○
	IMC1	D	DIMM030(D)	●	○
			DIMM031(J)	○	○
		E	DIMM040(E)	●	○
			DIMM041(K)	○	○
		F	DIMM050(F)	●	○
			DIMM051(L)	○	○
CPU2	IMC0	A	DIMM100(A)	●	○
			DIMM101(G)	○	○
		B	DIMM110(B)	●	○
			DIMM111(H)	○	○
		C	DIMM120(C)	●	○
			DIMM121(I)	○	○
	IMC1	D	DIMM130(D)	●	○
			DIMM131(J)	○	○
		E	DIMM140(E)	●	○
			DIMM141(K)	○	○
		F	DIMM150(F)	●	○
			DIMM151(L)	○	○

Figure 5-27 PMem installation guidelines (4 processor)

CPU	Channel	DIMM Slot	Installation Guideline (●: DDR4 ○: PMem)		
			AD	6+6	
CPU1	IMC0	A	DIMM000(A)	●	○
			DIMM001(G)	○	○
		B	DIMM010(B)	●	○
			DIMM011(H)	○	○
		C	DIMM020(C)	●	○
			DIMM021(I)	○	○
	IMC1	D	DIMM030(D)	●	○
			DIMM031(J)	○	○
		E	DIMM040(E)	●	○
			DIMM041(K)	○	○
		F	DIMM050(F)	●	○
			DIMM051(L)	○	○
CPU2	IMC0	A	DIMM100(A)	●	○
			DIMM101(G)	○	○
		B	DIMM110(B)	●	○
			DIMM111(H)	○	○
		C	DIMM120(C)	●	○
			DIMM121(I)	○	○
	IMC1	D	DIMM130(D)	●	○
			DIMM131(J)	○	○
		E	DIMM140(E)	●	○
			DIMM141(K)	○	○
		F	DIMM150(F)	●	○
			DIMM151(L)	○	○
CPU3	IMC0	A	DIMM200(A)	●	○
			DIMM201(G)	○	○
		B	DIMM210(B)	●	○
			DIMM211(H)	○	○
		C	DIMM220(C)	●	○
			DIMM221(I)	○	○
	IMC1	D	DIMM230(D)	●	○
			DIMM231(J)	○	○
		E	DIMM240(E)	●	○
			DIMM241(K)	○	○
		F	DIMM250(F)	●	○
			DIMM251(L)	○	○
CPU4	IMC0	A	DIMM300(A)	●	○
			DIMM301(G)	○	○
		B	DIMM310(B)	●	○
			DIMM311(H)	○	○
		C	DIMM320(C)	●	○
			DIMM321(I)	○	○
	IMC1	D	DIMM330(D)	●	○
			DIMM331(J)	○	○
		E	DIMM340(E)	●	○
			DIMM341(K)	○	○
		F	DIMM350(F)	●	○
			DIMM351(L)	○	○

5.4.2.6 Memory Protection Technologies

The following memory protection technologies are supported:

- PMem module Error Detection and Correction
- PMem module Device Failure Recovery (SDDC)
- PMem module Package Sparing (DDDC)
- PMem module Patrol Scrubbing
- PMem module Address Error Detection

- PMem module Data Poisoning (Corrupt Data Containment)
- PMem module Viral
- PMem module Address Range Scrub (ARS)
- PMem module Error Injection
- DDR-T Command and Address Parity Check and Retry
- DDR-T Read Write Data ECC Check and Retry
- PMem module Faulty DIMM Isolation
- PMem module Error Reporting

5.5 Storage

5.5.1 Drive Configurations

Table 5-11 Drive configuration

Configuration	Front Drive	Rear Drive	Built-in Drive	Drive Management Mode
8 x 2.5" drive pass-through configuration (8 x SAS/SATA)	<ul style="list-style-type: none"> • Front drive: 8 x 2.5" Slots 0 to 7 support only SAS/SATA drives. 	<ul style="list-style-type: none"> • 2 x M.2 SSDs <p>The Avago SAS3004iMR RAID controller card in slot 1 supports M.2 SSDs.</p>	<ul style="list-style-type: none"> • 2 x M.2 SSDs <p>The M.2 SSD adapter card in slot 10 supports M.2 SSDs.</p>	<ul style="list-style-type: none"> • SAS/SATA drive: <ul style="list-style-type: none"> – 1 x PCIe RAID controller card <p>The PCIe RAID controller card in slot 4 manages the SAS/SATA drives in slots 0 to 7.</p> • M.2 SSD: <ul style="list-style-type: none"> – PCH passthrough <p>Manages the M.2 SSDs on the M.2 SSD adapter card in</p>

Configuration	Front Drive	Rear Drive	Built-in Drive	Drive Management Mode
				slot 10. - Intel VROC (SATA RAID) Manages the M.2 SSDs on the M.2 SSD adapter card in slot 10. - 1 x PCIe RAID controller card. Manages the M.2 SSDs on the Avago SAS3004iMR PCIe RAID controller card in slot 1.
12 x 2.5" drive pass-through configuration (4 x SAS/SATA + 8 x NVMe)	<ul style="list-style-type: none"> • Front drive: 12 x 2.5" <ul style="list-style-type: none"> - Slots 0 to 3 support only SAS/SATA drives. - Slots 4 to 11 support only NVMe drives. 	<ul style="list-style-type: none"> • 2 x M.2 SSDs The Avago SAS3004iMR RAID controller card in slot 1 supports M.2 SSDs.	-	<ul style="list-style-type: none"> • SAS/SATA drive: <ul style="list-style-type: none"> - 1 x PCIe RAID controller card. The PCIe RAID controller card in slot 4 manages the SAS/SATA drives in slots 0 to 3. • NVMe

Configuration	Front Drive	Rear Drive	Built-in Drive	Drive Management Mode
				drive: <ul style="list-style-type: none"> - CPU Manages the NVMe drives in slots 4 to 11. • M.2 SSD: <ul style="list-style-type: none"> - 1 x PCIe RAID controller card. Manages the M.2 SSDs on the Avago SAS3004iMR PCIe RAID controller card in slot 1.
20 x 2.5" drive pass-through configuration (4 x SAS/SATA + 16 x NVMe)	<ul style="list-style-type: none"> • Front drive: 20 x 2.5" <ul style="list-style-type: none"> - Slots 0 to 3 support only SAS/SATA drives. - Slots 4 to 11 and slots 16 to 23 support only NVMe drives. 	<ul style="list-style-type: none"> • 2 x M.2 SSDs: The Avago SAS3004iMR RAID controller card in slot 1 supports M.2 SSDs. 	-	<ul style="list-style-type: none"> • SAS/SATA drive: <ul style="list-style-type: none"> - 1 x PCIe RAID controller card. The PCIe RAID controller card in slot 4 manages the SAS/SATA drives in slots 0 to 3. • NVMe drive: <ul style="list-style-type: none"> - CPU. Manages

Configuration	Front Drive	Rear Drive	Built-in Drive	Drive Management Mode
				<p>the NVMe drives in slots 4 to 11 and slots 16 to 23.</p> <ul style="list-style-type: none"> • M.2 SSD: <ul style="list-style-type: none"> - 1 x PCIe RAID controller card. Manages the M.2 SSDs on the Avago SAS3004iMR PCIe RAID controller card in slot 1.
<p>24 x 2.5" drive pass-through configuration (24 x SAS/SATA)</p>	<ul style="list-style-type: none"> • Front drive: 24 x 2.5" Slots 0 to 23 support only SAS/SATA drives. 	<ul style="list-style-type: none"> • 2 x M.2 SSDs: The Avago SAS3004iMR RAID controller card in slot 1 supports M.2 SSDs. 	<ul style="list-style-type: none"> • 2 x M.2 SSDs: The M.2 SSD adapter card in slot 10 supports M.2 SSDs. 	<ul style="list-style-type: none"> • SAS/SATA drive: <ul style="list-style-type: none"> - 3 x PCIe RAID controller cards. - The PCIe RAID controller card in slot 2 manages the drives in slots 8 to 15. - The PCIe RAID controller card in slot 4 manages the drives in

Configuration	Front Drive	Rear Drive	Built-in Drive	Drive Management Mode
				<p>slots 0 to 7.</p> <ul style="list-style-type: none"> - The PCIe RAID controller card in slot 5 manages the drives in slots 16 to 23. • M.2 SSD: <ul style="list-style-type: none"> - PCH passthrough. Manages the M.2 SSDs on the M.2 SSD adapter card in slot 10. - Intel VROC (SATA RAID). Manages the M.2 SSDs on the M.2 SSD adapter card in slot 10. - 1 x PCIe RAID controller card. Manages the M.2 SSDs on the Avago SAS3004iMR PCIe RAID

Configuration	Front Drive	Rear Drive	Built-in Drive	Drive Management Mode
				controller card in slot 1.
25 x 2.5" drive EXP configuration (25 x SAS/SATA)	<ul style="list-style-type: none"> Front drive: 25 x 2.5" Slots 0 to 24 support only SAS/SATA drives. 	<ul style="list-style-type: none"> 2 x M.2 SSDs: The Avago SAS3004iMR RAID controller card in slot 1 supports M.2 SSDs. 	<ul style="list-style-type: none"> 2 x M.2 SSDs: The M.2 SSD adapter card in slot 10 supports M.2 SSDs. 	<ul style="list-style-type: none"> SAS/SATA drive: <ul style="list-style-type: none"> 1 x PCIe RAID controller card. The PCIe RAID controller card in slot 4 manages the SAS/SATA drives in slots 0 to 24. M.2 SSD: <ul style="list-style-type: none"> PCH passthrough. Manages the M.2 SSDs on the M.2 SSD adapter card in slot 10. Intel VROC (SATA RAID). Manages the M.2 SSDs on the M.2 SSD adapter card in slot 10. 1 x PCIe RAID controller

Configuration	Front Drive	Rear Drive	Built-in Drive	Drive Management Mode
				r card. Manages the M.2 SSDs on the Avago SAS300 4iMR PCIe RAID controller card in slot 1.
Note: For details about component options, consult the local sales representatives.				

5.5.2 Drive Numbering

NOTICE

The drive numbers identified by the RAID controller card vary depending on the cabling of the RAID controller card. The drive numbers identified by the RAID controller card in this section are provided based on the default cabling described in "Internal Cabling" in *FusionServer 2488H V6 Server Maintenance and Service Guide*.

- 8 x 2.5" drive pass-through configuration (8 x SAS/SATA)

Figure 5-28 Slot numbers

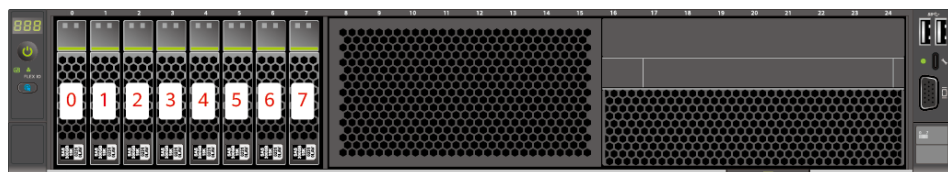

Table 5-12 Slot numbers

Drive No.	Drive Number Identified by the iBMC	Drive Number Identified by the RAID Controller
0	0	0
1	1	1
2	2	2

Drive No.	Drive Number Identified by the iBMC	Drive Number Identified by the RAID Controller
3	3	3
4	4	4
5	5	5
6	6	6
7	7	7

- 12 x 2.5" drive pass-through configuration (4 x SAS/SATA + 8 x NVMe)

Figure 5-29 Slot numbers

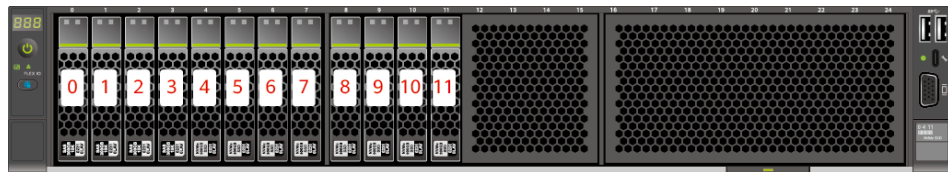

Table 5-13 Slot numbers

Drive No.	Drive Number Identified by the iBMC	Drive Number Identified by the RAID Controller
0	0	0
1	1	1
2	2	2
3	3	3
4	4	-
5	5	-
6	6	-
7	7	-
8	8	-
9	9	-
10	10	-
11	11	-

- 20 x 2.5" drive pass-through configuration (4 x SAS/SATA + 16 x NVMe)

Figure 5-30 Slot numbers

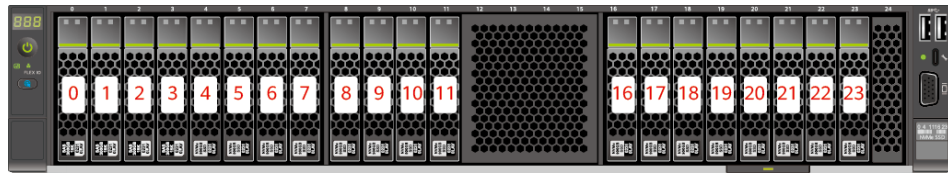

Table 5-14 Slot numbers

Drive No.	Drive Number Identified by the iBMC	Drive Number Identified by the RAID Controller
0	0	0
1	1	1
2	2	2
3	3	3
4	4	-
5	5	-
6	6	-
7	7	-
8	8	-
9	9	-
10	10	-
11	11	-
16	16	-
17	17	-
18	18	-
19	19	-
20	20	-
21	21	-
22	22	-
23	23	-

- 24 x 2.5" drive pass-through configuration (24 x SAS/SATA)

Figure 5-31 Slot numbers



Table 5-15 Slot numbers

Drive No.	Drive Number Identified by the iBMC	Drive Number Identified by the RAID Controller
0	0	0
1	1	1
2	2	2
3	3	3
4	4	4
5	5	5
6	6	6
7	7	7
8	8	0
9	9	1
10	10	2
11	11	3
12	12	4
13	13	5
14	14	6
15	15	7
16	16	0
17	17	1
18	18	2
19	19	3
20	20	4
21	21	5
22	22	6
23	23	7

- 25 x 2.5" drive EXP configuration (25 x SAS/SATA)

Figure 5-32 Slot numbers



Table 5-16 Slot numbers

Drive No.	Drive Number Identified by the iBMC	Drive Number Identified by the RAID Controller
0	0	0
1	1	1
2	2	2
3	3	3
4	4	4
5	5	5
6	6	6
7	7	7
8	8	8
9	9	9
10	10	10
11	11	11
12	12	12
13	13	13
14	14	14
15	15	15
16	16	16
17	17	17
18	18	18
19	19	19
20	20	20

Drive No.	Drive Number Identified by the iBMC	Drive Number Identified by the RAID Controller
21	21	21
22	22	22
23	23	23
24	24	24

5.5.3 Drive Indicators

SAS/SATA Drive Indicators

Figure 5-33 SAS/SATA drive indicators

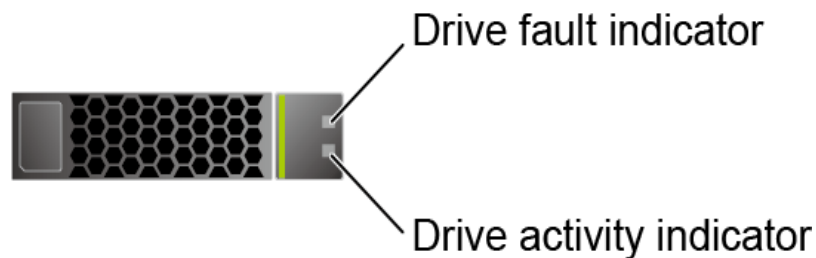

Table 5-17 SAS/SATA drive indicators

Activity Indicator (Green)	Fault Indicator (Yellow)	Description
Off	Off	The drive is not in position.
Steady on	Off	The drive is detected.
Blinking at 4 Hz	Off	Data is being read or written properly, or data on the primary drive is being rebuilt.
Steady on	Blinking at 1 Hz	The drive is being located.
Blinking at 1 Hz	Blinking at 1 Hz	Data on the secondary drive is being rebuilt.
Off	Steady on	A drive in a RAID array is removed.
Steady on	Steady on	The drive is faulty.

NVMe Drive Indicators

Figure 5-34 NVMe drive indicators

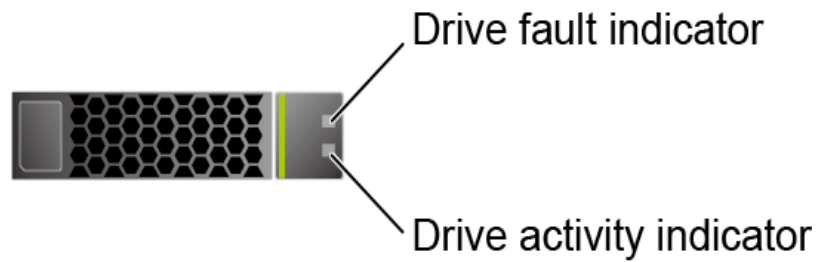

Table 5-18 NVMe drive indicators

Active Indicator (Green)	Fault Indicator (Yellow)	State Description
Off	Off	The NVMe drive is not detected.
Steady on	Off	The NVMe drive is detected and operating properly.
Blinking at 2 Hz	Off	Data is being read from or written to the NVMe drive.
Off	Blinking at 2 Hz	The NVMe drive is being located or hot-swapped.
Off	Blinking at 0.5 Hz	The NVMe drive has completed the hot swap process and is removable.
Steady on/off	Steady on	The NVMe drive is faulty.

M.2 FRU Indicators

The server supports the Avago SAS3004iMR RAID controller card, which supports two M.2 FRUs.

Figure 5-35 M.2 FRU indicators

M.2 FRU fault indicator M.2 FRU activity indicator



Table 5-19 M.2 FRU indicators

M.2 FRU Active Indicator (Green)	M.2 FRU Fault Indicator (Yellow)	Description
Off	Off	The M.2 FRU is not detected.
Steady on	Off	The M.2 FRU is inactive.
Blink	Off	The M.2 FRU is in the read/write or synchronization state.
Steady on	Blink	The M.2 FRU is being located.
Blink	Blink	The RAID array is being rebuilt.
Off	Steady on	The M.2 FRU cannot be detected or is faulty.
Steady on	Steady on	The M.2 FRU RAID status is abnormal.

5.5.4 RAID Controller Card

The RAID controller card supports RAID configuration, RAID level migration, and drive roaming.

- Contact your local sales representative or see "Search Parts" in the [Compatibility Checker](#) to determine the components to be used.
- For details about the RAID controller card, see *V6 Server RAID Controller Card User Guide*.

5.6 Network

5.6.1 OCP 3.0 Network Adapter

OCP 3.0 network adapters provide network expansion capabilities.

- The FlexIO slot supports only the OCP 3.0 network adapter, which can be configured as required.
- Contact your local sales representative or see "Search Parts" in the [Compatibility Checker](#) to determine the components to be used.
- For details about the OCP 3.0 network adapter, see the documents of each OCP 3.0 network adapter.

5.7 I/O Expansion

5.7.1 PCIe Cards

PCIe cards provide ease of expandability and connection.

- A maximum of 11 PCIe 3.0 slots are supported, including one slot dedicated for the OCP 3.0 network adapter.
- Contact your local sales representative or see "Search Parts" in the [Compatibility Checker](#) to determine the components to be used.
- When IB cards are used to build an IB network, ensure that the IPoIB modes of the IB cards at both ends of the network are the same. For details, contact technical support.

5.7.2 PCIe Slots

PCIe Slots

Figure 5-36 PCIe slots

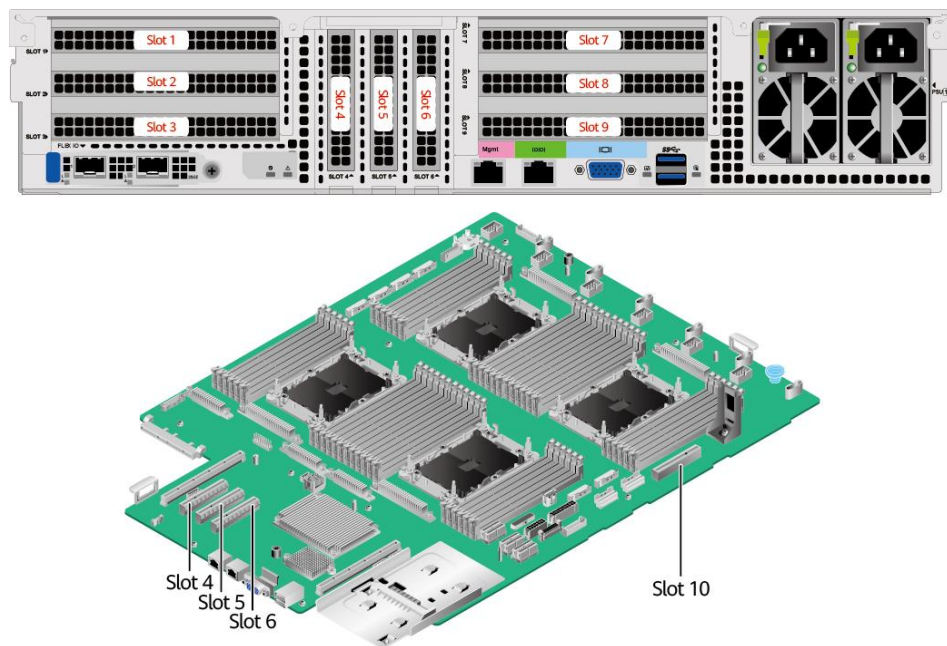

- PCIe riser module 1 provides slots 1, 2, and 3. If a dual-slot PCIe riser module is used, slot 3 is unavailable.
- PCIe riser module 2 provides slots 7, 8, and 9. If a dual-slot PCIe riser module is used, slot 9 is unavailable.
- The mainboard provides slots 4, 5, 6, and 10.

PCIe Riser Modules

- PCIe riser module (universal 3-slot)
 - Provides PCIe slots 1, 2, and 3 when installed in PCIe riser module 1.
 - Provides PCIe slots 7, 8, and 9 when installed in PCIe riser module 2.

Figure 5-37 PCIe riser module (universal 3-slot)

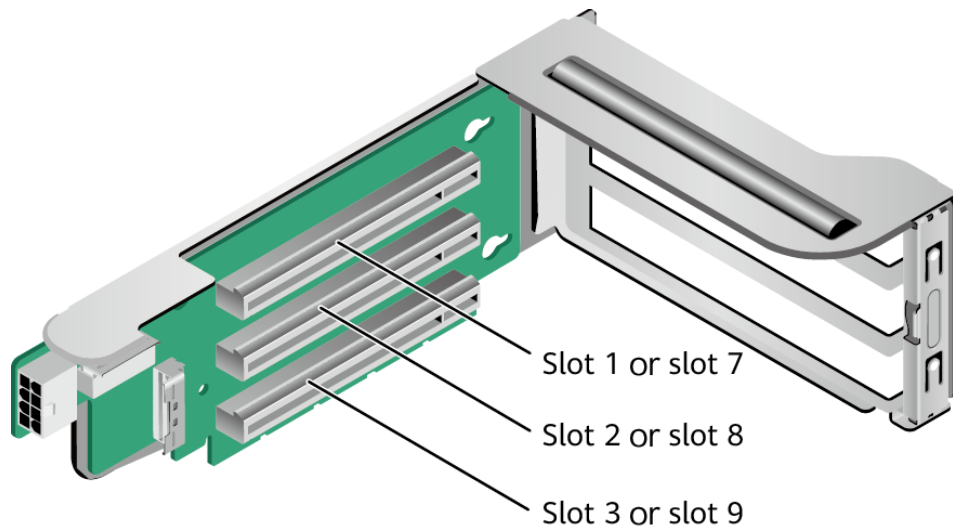

- PCIe riser module (universal 2-slot)
 - Provides PCIe slots 1 and 2 when installed in PCIe riser module 1.
 - Provides PCIe slots 7 and 8 when installed in PCIe riser module 2.

Figure 5-38 PCIe riser module (universal 2-slot)

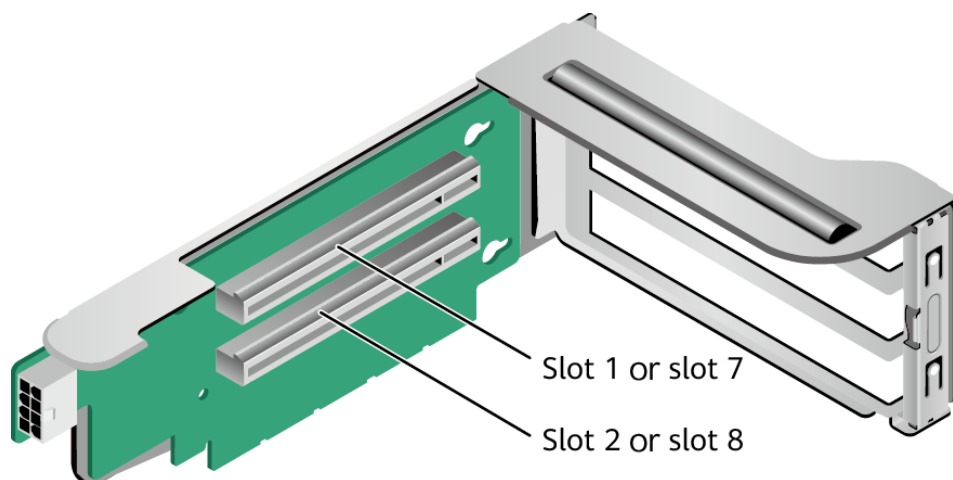

- PCIe riser module (universal 3-slot, supporting GPUs)
 - Provides PCIe slots 1, 2, and 3 when installed in PCIe riser module 1.
 - Provides PCIe slots 7, 8, and 9 when installed in PCIe riser module 2.

NOTE

A full-height full-length dual-width GPU occupies an adjacent slot.

Figure 5-39 PCIe riser module (universal 3-slot, supporting GPUs)

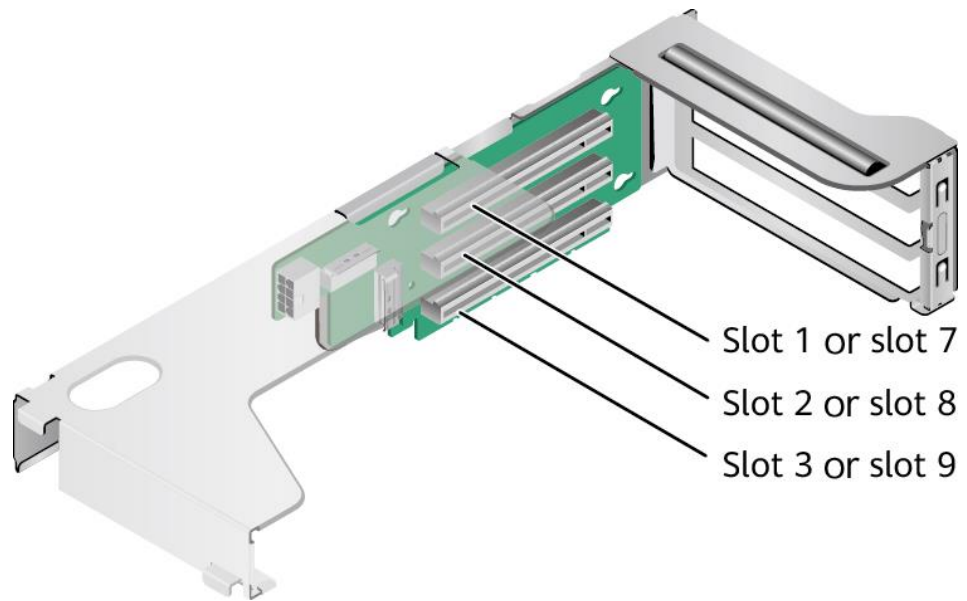

- PCIe riser module (universal 2-slot, supporting GPUs)
 - Provides PCIe slots 1 and 2 when installed in PCIe riser module 1.
 - Provides PCIe slots 7 and 8 when installed in PCIe riser module 2.

NOTE

A full-height full-length dual-width GPU occupies an adjacent slot.

Figure 5-40 PCIe riser module (universal 2-slot, supporting GPUs)

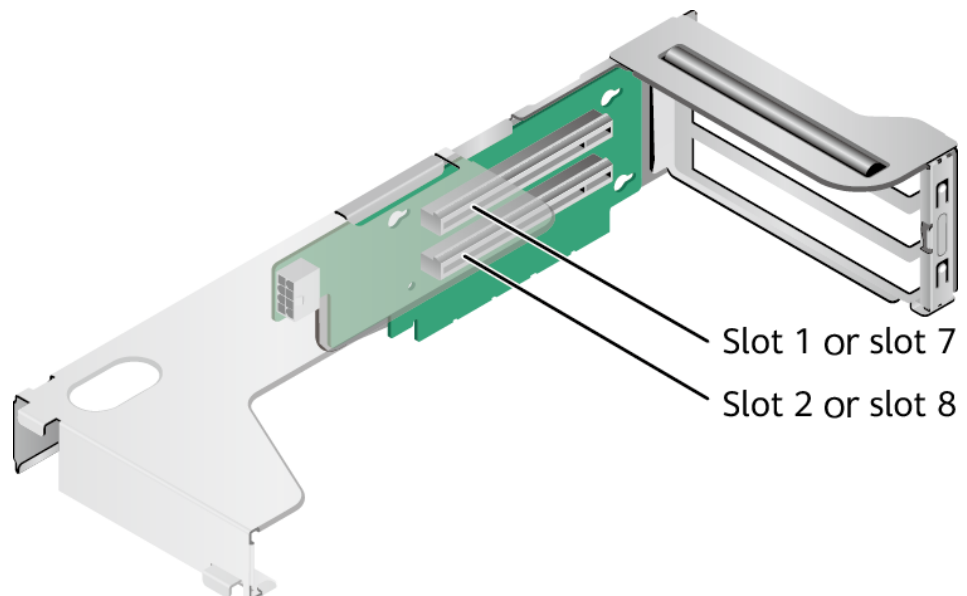

5.7.3 PCIe Slot Description

 **NOTE**

The PCIe slots mapping to a vacant CPU socket are unavailable.

Table 5-20 PCIe slot description

PCIe Slot	CPU	PCIe Standards	Connector Width	Bus Width	Port No.	Root Port (B/D/F)	Device (B/D/F)	Slot Size
FlexIO card	CPU 1	PCIe 3.0	x16	x16	Port1A	0x15/0/0	0x16/0/0	OCPC 3.0 specifications
Slot 1	CPU 1	PCIe 3.0	x16	x8	Port2A	0x23/0/0	0x24/0/0	FHFL
Slot 2	CPU 1	PCIe 3.0	x16	x16	Port4A	0x32/0/0	0x33/0/0	FHFL
Slot 3	CPU 4	PCIe 3.0	x16	<ul style="list-style-type: none"> • 2-slot PCI e riser module (PRM): N/A • 3-slot PRM: x16 	Port1A	0xC3/0/0	0xC4/0/0	FHHL
Slot 4	CPU 1	PCIe 3.0	x8	x8	Port2C	0x23/2/0	0x25/0/0	HHHL
Slot 5	CPU 2	PCIe 3.0	x8	x8	Port4A	0x6C/0/0	0x6D/0/0	HHHL
Slot 6	CPU 2	PCIe 3.0	x8	x8	Port4C	0x6C/2/0	0x6E/0/0	HHHL
Slot 7	CPU 2	PCIe 3.0	x16	x8	Port1A	0x43/0/0	0x44/0/0	FHFL
Slot 8	CPU 2	PCIe 3.0	x16	x16	Port2A	0x57/0/0	0x58/0/0	FHFL
Slot 9	CPU 3	PCIe 3.0	x16	<ul style="list-style-type: none"> • 2-slot 	Port1A	0x83/0/0	0x84/0/0	FHHL

PCIe Slot	CPU	PCIe Standards	Connector Width	Bus Width	Port No.	Root Port (B/D/F)	Device (B/D/F)	Slot Size
				PRM: N/A <ul style="list-style-type: none"> 3-slot PRM: x16 				
Slot 10	CPU 2	PCIe 3.0	x8	x8	Port1C	0x43/2/0	0x45/0/0	HHHL

- The B/D/F (Bus/Device/Function Number) is the default value when the server is fully configured with PCIe cards. The value may differ if the server is not fully configured with PCIe cards or if a PCIe card with a PCI bridge is configured.
- Root Port (B/D/F) indicates the B/D/F of an internal PCIe root port of the processor.
- Device (B/D/F) indicates the B/D/F (bus address displayed on the OS) of an onboard or extended PCIe device.
- The PCIe x16 slots are compatible with PCIe x16, PCIe x8, PCIe x4, and PCIe x1 cards. The PCIe cards are not forward compatible. That is, the PCIe slot width cannot be smaller than the PCIe card link width.
- The full-height full-length (FHFL) PCIe slots are compatible with FHFL PCIe cards, full-height half-length (FHHL) PCIe cards, and half-height half-length (HHHL) PCIe cards.
- The full-height half-length (FHHL) PCIe slots are compatible with FHHL PCIe cards and half-height half-length (HHHL) PCIe cards.
- The maximum power supply of each PCIe slot is 75 W.

5.8 PSUs

- The server supports one or two PSUs.
- The server supports AC or DC PSUs.
- The PSUs are hot-swappable.
- The server supports two PSUs in 1+1 redundancy.
- PSUs of the same part number (P/N code) must be used in a server.
- The PSUs are protected against short circuit. Double-pole fuse is provided for the PSUs with dual input live wires.
- If the DC power supply is used, purchase the DC power supply that meets the requirements of the safety standards or the DC power supply that has passed the CCC certification.
- Contact your local sales representative or see "Search Parts" in the [Compatibility Checker](#) to determine the components to be used.

Figure 5-41 Positions of PSUs

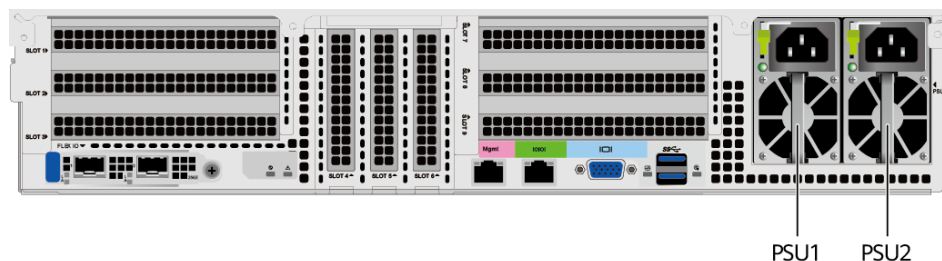

NOTE

- When one or two 900 W AC Titanium PSUs are configured and the input voltage ranges from 100 V AC to 127 V AC, the output power decreases to 550 W.
- When one or two 2000 W AC Platinum PSUs are configured and the input voltage ranges from 200 V AC to 220 V AC, the output power decreases to 1800 W.
- When one or two 3000 W AC Titanium PSUs are configured:
 - If the input voltage ranges from 100 V AC to 127 V AC, the output power decreases to 1300 W.
 - If the input voltage ranges from 200 V AC to 220 V AC, the output power decreases to 2500 W.
 - If the input voltage ranges from 220 V AC to 230 V AC, the output power decreases to 2900 W.

5.9 Fan Modules

- The server supports six fan modules.
- The fan modules are hot-swappable.
- N+1 redundancy is supported. That is, the server can work properly when a single fan fails.
- The fan speed can be adjusted.
- Fan modules of the same part number (P/N code) must be used in a server.

Figure 5-42 Positions of fan modules

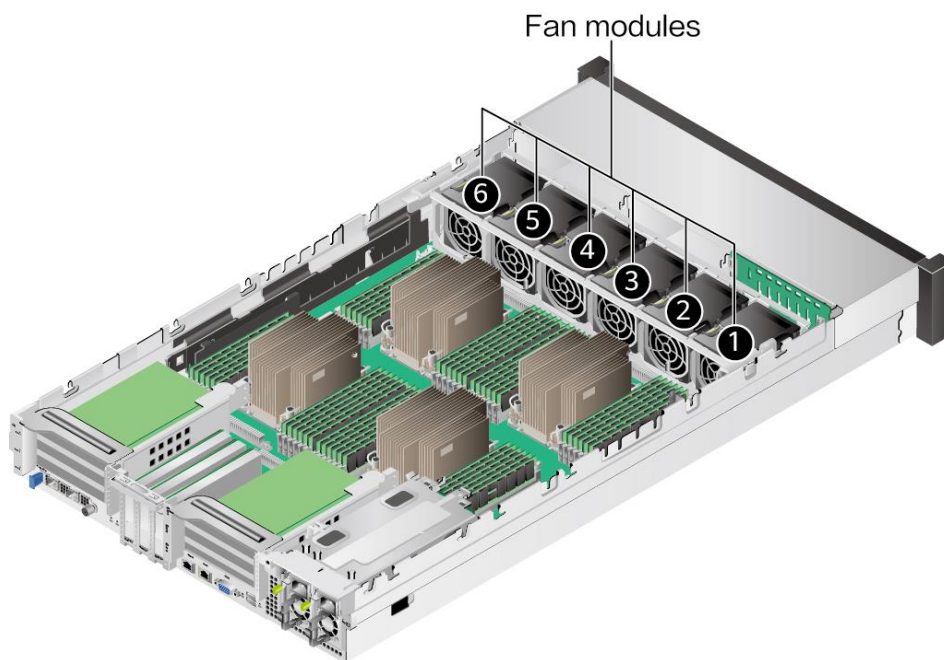

5.10 LCD

 **NOTE**

Only the 8 x 2.5" drive pass-through configuration (8 x SAS/SATA) supports the LCD.

Function

The LCD displays the installation status and running status of server components and enables users to set the IP address of the iBMC management network port on the server.

The LCD and the server iBMC form an LCD subsystem. The LCD directly obtains device information from the iBMC. The LCD subsystem does not store device data.

Figure 5-43 LCD subsystem working principle

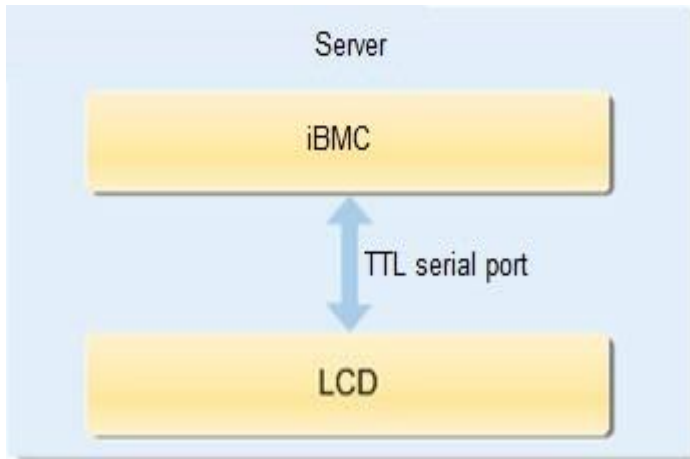

UI

Figure 5-44 LCD main interface

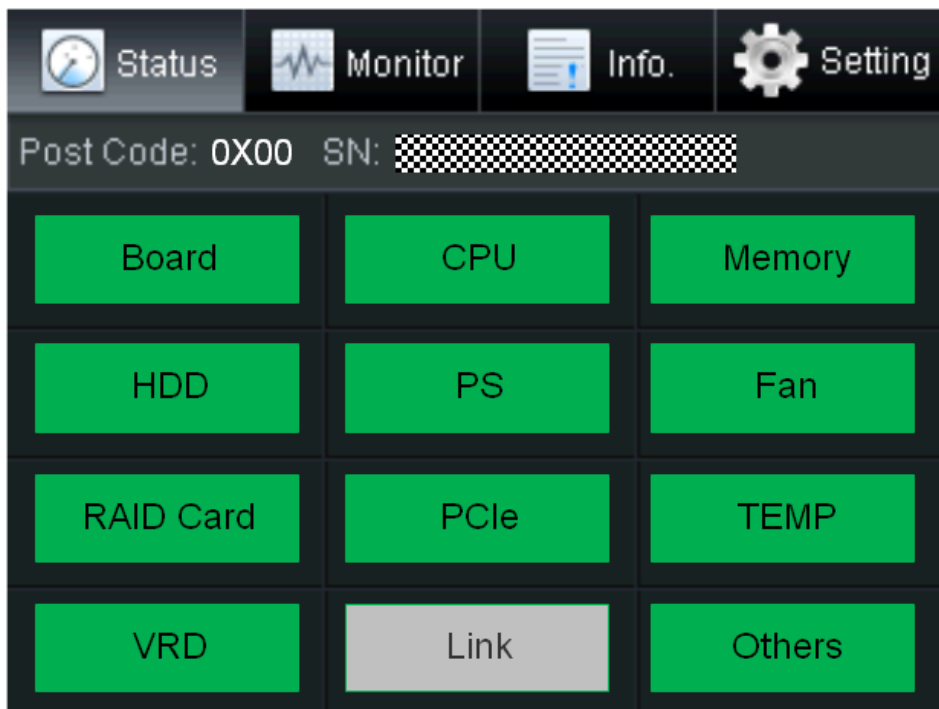

Table 5-21 Parameters on the LCD home screen

Tab	Function
Status	Displays the port 80 status, serial number, component status, and component alarms of the server.
Monitor	Displays the current power, CPU temperature, and inlet

Tab	Function
	temperature of the server.
Info.	Displays the IP address and MAC address of the iBMC management network port, device SNs, asset information, and firmware version.
Setting	Sets the IP address of the iBMC management network port.

For details about how to use the LCD module, see *FusionServer Rack Server LCD User Guide (x86 V6)*.

5.11 Boards

5.11.1 Mainboard

Figure 5-45 2488H V6 mainboard

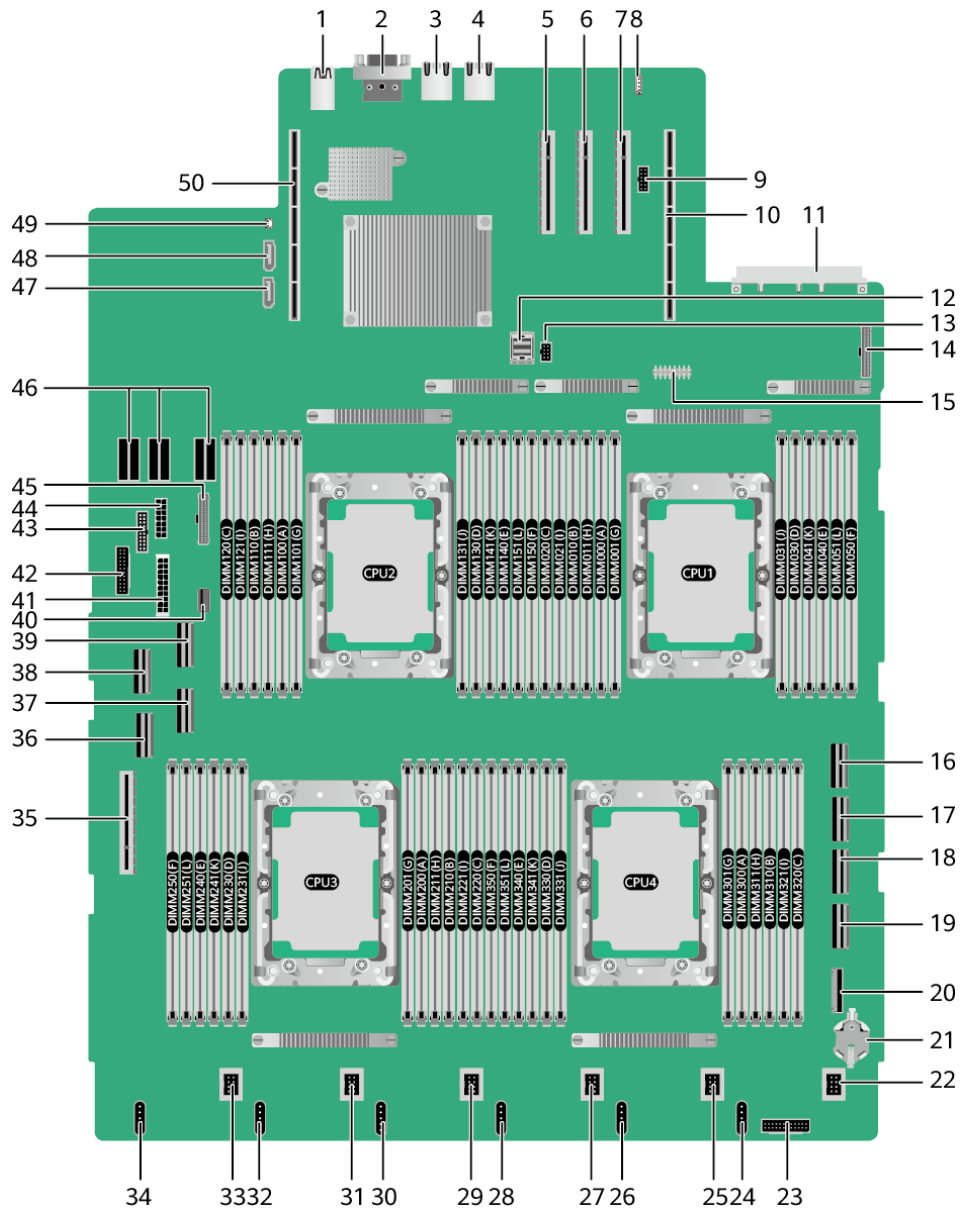

1	Rear USB 3.0 port (USB3.0x2/J80)	2	VGA port (VGA CONN/J14)
3	Serial port (IO/IO/J148)	4	BMC management network port (BMC Mesg/J149)
5	PCIe slot 6 (PCIe SLOT(CPU2) X8/J132)	6	PCIe slot 5 (PCIe SLOT(CPU2) X8/J131)

7	PCIe slot 4 (PCIE SLOT(CPU1) X8/J130)	8	VROC key connector (SOFT RAID KEY/J1) ^a
9	NC-SI connector (NCSI CONN/J129)	10	PCIe riser 1 slot (PCIE RISER1(CPU1)/J87)
11	OCP 3.0 network adapter connector (OCP CONN/J138)	12	Mini-SAS HD connector (Mini SAS CONN/J13)
13	PCIe smart card serial port connector (J150)	14	Right mounting ear connector (RIGHT EAR CONN/J76)
15	TPM/TCM connector (TPM CONN/J85)	16	LP slimline 1D connector (Slimline_1D/J71)
17	LP slimline 1C connector (Slimline_1C/J69)	18	LP slimline 1 connector (Slimline_1/J68)
19	LP slimline 2 connector (Slimline_2/J70)	20	LCD connector (LCD CONN/J15)
21	Cell battery holder (CMOS BAT/U207)	22	6076 fan module connector 6 (FAN6/J12)
23	Fan board connector (POD7/J72) ^a	24	6038 fan module connector 6 (FAN6/POD6/J2007)
25	6076 fan module connector 5 (FAN5/J11)	26	6038 fan module connector 5 (FAN5/POD5/J2006)
27	6076 fan module connector 4 (FAN4/J8)	28	6038 fan module connector 4 (FAN4/POD4/J2005)
29	6076 fan module connector 3 (FAN3/J7)	30	6038 fan module connector 3 (FAN3/POD3/J2004)
31	6076 fan module connector 2 (FAN2/J4)	32	6038 fan module connector 2 (FAN2/POD2/J2003)
33	6076 fan module connector 1 (FAN1/J2)	34	6038 fan module connector 1 (FAN1/POD1/J2002)
35	PCIe slot 10 (PCIE SLOT(CPU2) X8/J133)	36	LP slimline 4 connector (Slimline_4/J66)
37	LP slimline 2D connector (Slimline_2D/J64)	38	LP slimline 3 connector (Slimline3/J67)
39	LP slimline 2C connector (Slimline_2C/J65)	40	Built-in USB 3.0 port (USB3.0/J75)
41	20-pin power connector for the drive backplane (HDD BP POWER/J5)	42	Left mounting ear connector (LEFT EAR CONN/J9)
43	Signal connector for the drive backplane (HDD BP MIS/J81)	44	14-pin power connector for the drive backplane (HDD BP POWER2/J6)
45	Signal connector for the PSU	46	Power connectors for the PSU

	backplane (PDB MIS CONN/J10)		backplane (PDB POWER CONN/J153/J154/J155)
47	SATA connector 2/DVD drive connector (SATA2/DVD/J74)	48	SATA connector 1 (SATA1/J73)
49	Intrusion sensor connector (S1)	50	PCIe riser 2 slot (PCIE RISER2(CPU2)/J88)
a: Reserved and unavailable currently.			

5.11.2 Drive Backplane

Front-Drive Backplane

- 8 x 2.5" drive pass-through backplane (8 x SAS/SATA)

Figure 5-46 8 x 2.5" drive pass-through backplane (8 x SAS/SATA)

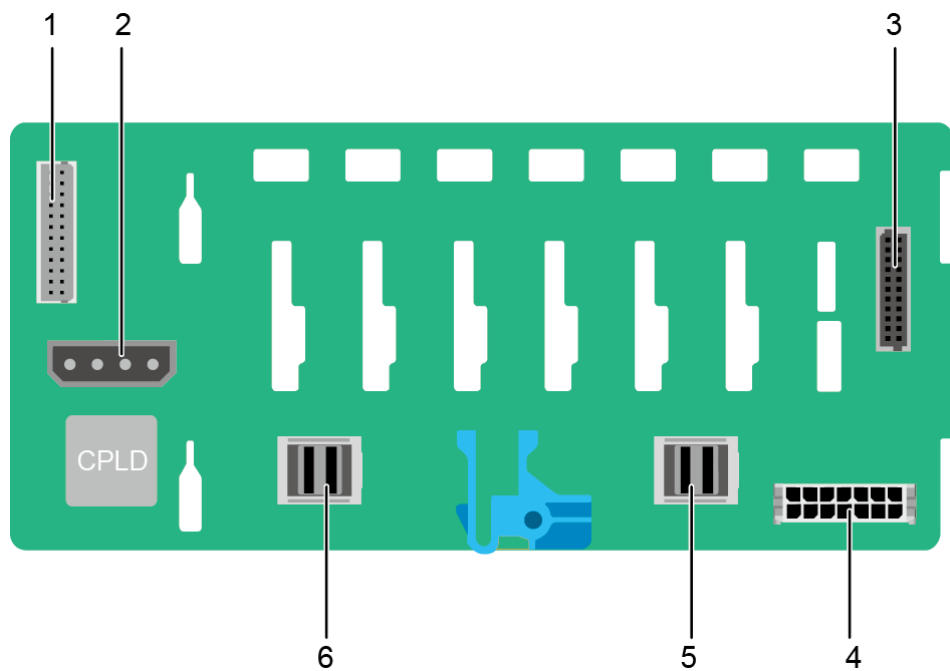

1	Indicator signal cable connector (REAR BP1/J3)	2	DVD drive power connector (DVD/J11)
3	Backplane signal cable connector (HDD BP/J1)	4	Power connector (POWER/J2)
5	Mini-SAS HD Port A connector (PORTA/J28)	6	Mini-SAS HD Port B connector (PORTB/J29)

- 12 x 2.5" drive pass-through backplane (4 x SAS/SATA + 8 x NVMe)

Figure 5-47 12 x 2.5" drive pass-through backplane (4 x SAS/SATA + 8 x NVMe)

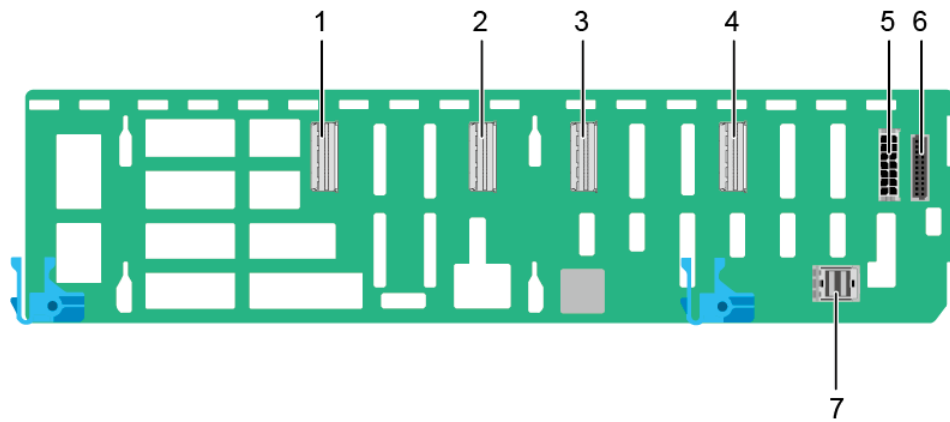

1	LP slimline 2 connector (SLIM_2/J1001)	2	LP slimline 1 connector (SLIM_1/J901)
3	LP slimline 4 connector (SLIM_4/J1201)	4	LP slimline 3 connector (SLIM_3/J1101)
5	Power connector (HDD POWER/J4003)	6	Backplane signal cable connector (HDD_BP/J3702)
7	Mini-SAS HD Port A connector (PORTA/J801)	-	-

- 20 x 2.5" drive pass-through backplane (4 x SAS/SATA + 16 x NVMe)

Figure 5-48 20 x 2.5" drive pass-through backplane (4 x SAS/SATA + 16 x NVMe)

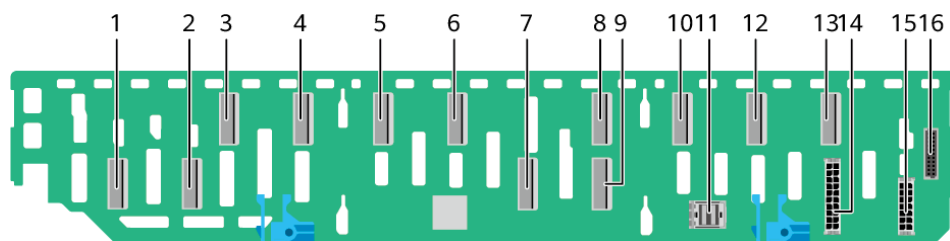

1	LP slimline 2 connector (Slimline2/J1201)	2	LP slimline 1 connector (Slimline1/J1101)
3	LP slimline 1D connector (Slimline_1D/J1801)	4	LP slimline 1C connector (Slimline_1C/J1701)
5	LP slimline 1A connector (Slimline_1A/J1601)	6	LP slimline 1B connector (Slimline_1B/J1501)

7	LP slimline 4 connector (Slimline4/J1401)	8	LP slimline 2D connector (Slimline_2D/J2201)
9	LP slimline 3 connector (Slimline3/J1301)	10	LP slimline 2C connector (Slimline_2C/J2101)
11	Mini-SAS HD Port A connector (PORTA/J1001)	12	LP slimline 2B connector (Slimline_2B/J2001)
13	LP slimline 2A connector (Slimline_2A/J1901)	14	20-pin power connector for the drive backplane (HDD_Power2/J7303)
15	14-pin power connector for the drive backplane (HDD_Power1/J30)	16	Signal connector for the drive backplane (HDD_BP/J7102)

- 24 x 2.5" drive pass-through backplane (24 x SAS/SATA)

Figure 5-49 24 x 2.5" drive pass-through backplane (24 x SAS/SATA)

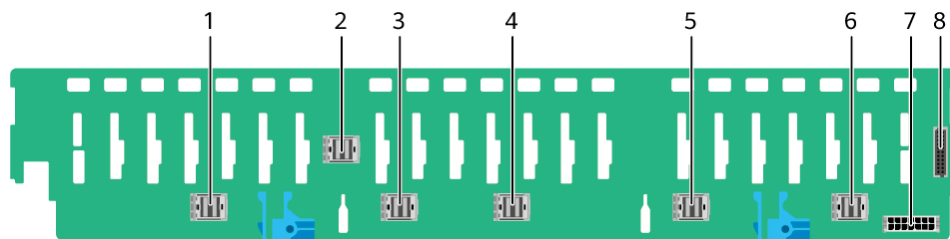

1	Mini-SAS HD Port 3B connector (PORT3B/J33)	2	Mini-SAS HD Port 3A connector (PORT3A/J39)
3	Mini-SAS HD Port 2B connector (PORT2B/J31)	4	Mini-SAS HD Port 2A connector (PORT2A/J30)
5	Mini-SAS HD Port 1B connector (PORT1B/J29)	6	Mini-SAS HD Port 1A connector (PORT1A/J28)
7	Power connector for the PSU backplane (POWER/J24)	8	Signal connector for the drive backplane (HDD_BP/J1)

- 25 x 2.5" drive EXP backplane (25 x SAS/SATA)

Figure 5-50 25 x 2.5" drive EXP backplane (25 x SAS/SATA)

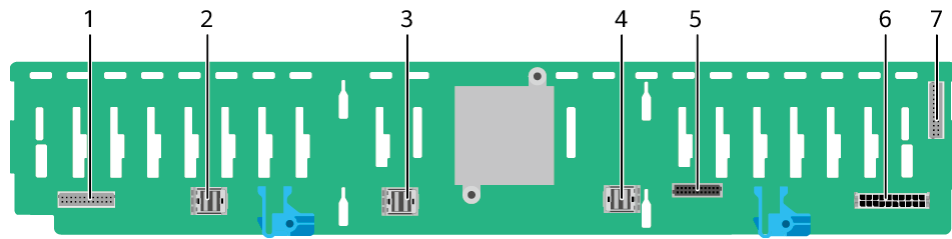

1	Signal connector for the rear backplane (REAR BP0/J32) ^a	2	Mini-SAS HD Port A connector (PORTA/J28)
3	Mini-SAS HD Port B connector (PORTB/J29)	4	Mini-SAS HD Rear Port connector (REAR PORT/J31) ^a
5	Signal connector for the drive backplane (HDD_BP/J1)	6	Power connector for the drive backplane (POWER/J24)
7	Signal connector for the built-in backplane (REAR BP1/J35) ^a	-	-

a: Reserved and unavailable currently.

5.11.3 PSU Backplane

Figure 5-51 2488H V6 PSU backplane

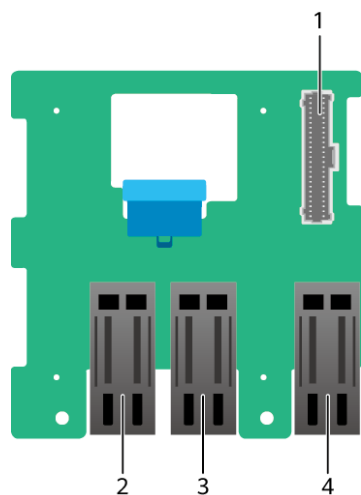

1	Signal connector for the PSU backplane (J306)	2	Power connector (J304)
3	Power connector (J303)	4	Power connector (J305)

6 Product Specifications

- 6.1 [Technical Specifications](#)
- 6.2 [Environmental Specifications](#)
- 6.3 [Physical Specifications](#)

6.1 Technical Specifications

Table 6-1 Technical specifications

Component	Specifications
Form factor	2U rack server
Chipset	Intel® C621A
Processor	<p>Supports two or four processors.</p> <ul style="list-style-type: none"> • Third-generation Intel® Xeon® Scalable Cooper Lake processors • Built-in memory controller and six memory channels per processor • Built-in PCIe controller, supporting PCIe 3.0 and 48 lanes per processor • Six UPI buses between processors, providing up to 10.4 GT/s transmission per channel • Up to 28 cores per processor • Max. 3.9 GHz • Min. 1.375 MB L3 cache per core • Max. 250 W TDP <p>NOTE The preceding information is for reference only. For details, see "Search Parts" in the Compatibility Checker.</p>
DIMM	<p>Supports 48 memory module slots.</p> <ul style="list-style-type: none"> • Up to 48 DDR4 memory modules

Component	Specifications
	<ul style="list-style-type: none"> - Max. 3200 MT/s memory speed - RDIMM and LRDIMM support - The DDR4 memory modules of different types (RDIMM and LRDIMM) and specifications (capacity, bit width, rank, and height) cannot be used together. - A server must use DDR4 memory modules of the same part number (P/N code). • Up to 24 PMem modules <ul style="list-style-type: none"> - The PMem modules must be used with the DDR4 memory modules, and the DDR4 memory module can be installed only in the memory slot of the primary memory channel. - The PMem module supports only the AD mode. - Max. 2666 MT/s memory speed - The PMem modules of different specifications (capacity and rank) cannot be used together. - For details about the PMem modules, see <i>FusionServer PMem 200 User Guide</i>. <p>NOTE The preceding information is for reference only. For details, see "Search Parts" in the Compatibility Checker.</p>
Storage	<p>Supports a variety of drive configurations. For details, see 5.5.1 Drive Configurations .</p> <ul style="list-style-type: none"> • Supports M.2 SSDs. <ul style="list-style-type: none"> - M.2 SSDs are supported for RAID configuration when the server is configured with an Avago SAS3004iMR RAID controller card. - M.2 SSDs are supported for VROC (SATA RAID) configuration when the server is configured with an M.2 SSD adapter card. <p>NOTE</p> <ul style="list-style-type: none"> • The M.2 SSD is used only as a boot device for installing the OS. Small-capacity (32 GB or 64 GB) M.2 SSDs do not support logging due to poor endurance. If a small-capacity M.2 SSD is used as the boot device, a dedicated log drive or log server is required for logging. For example, you can dump VMware logs in either of the following ways: • Redirect /scratch. For details, see https://kb.vmware.com/s/article/1033696. • Configure syslog. For details, see https://kb.vmware.com/s/article/2003322. • The M.2 SSD cannot be used to store data due to poor endurance. In write-intensive applications, the M.2 SSD will wear out in a short time. <p>If you want to use SSDs or HDDs as data storage devices, use enterprise-level SSDs or HDDs with high DDPD.</p> <ul style="list-style-type: none"> • The M.2 SSD is not recommended for write-intensive service software due to poor endurance.

Component	Specifications
	<ul style="list-style-type: none"> • Do not use M.2 SSDs for cache. • Supports hot swap of SAS/SATA/NVMe drives. <p>NOTE The NVMe drives support only orderly hot swap.</p> <ul style="list-style-type: none"> • Supports a variety of RAID controller cards. For details, consult the local sales representative. <ul style="list-style-type: none"> – The RAID controller card supports RAID configuration, RAID level migration, and drive roaming. – The RAID controller card supports a supercapacitor for power-off protection to ensure user data security. – The PCIe RAID controller card occupies one PCIe slot. <p>For details about the RAID controller card, see <i>V6 Server RAID Controller Card User Guide</i>.</p> <p>NOTE If the BIOS is in legacy mode, the 4K drive cannot be used as the boot drive.</p>
Network	<p>Supports expansion capability of multiple types of networks.</p> <ul style="list-style-type: none"> • OCP 3.0 network adapter <ul style="list-style-type: none"> – The FlexIO slot supports only the OCP 3.0 network adapter, which can be configured as required. – Supports a variety of OCP 3.0 network adapters. For details, see "Search Parts" in the Compatibility Checker.
I/O expansion	<p>Supports 11 PCIe 3.0 slots.</p> <ul style="list-style-type: none"> • One FlexIO slot dedicated for an OCP 3.0 network adapter, six PCIe slots on the riser card, and four onboard PCIe slots. <p>For details, see 5.7.2 PCIe Slots and 5.7.3 PCIe Slot Description.</p> <ul style="list-style-type: none"> • Two full-height full-length dual-width GPU cards. <p>NOTE The preceding information is for reference only. For details, see "Search Parts" in the Compatibility Checker.</p>
Port	<p>Supports a variety of ports.</p> <ul style="list-style-type: none"> • Ports on the front panel: <ul style="list-style-type: none"> – Two USB 3.0 ports – One USB Type-C iBMC direct connect management port – One DB15 VGA port • Ports on the rear panel: <ul style="list-style-type: none"> – Two USB 3.0 ports – One DB15 VGA port – One RJ45 serial port – One RJ45 management network port

Component	Specifications
	<ul style="list-style-type: none"> • Built-in ports: <ul style="list-style-type: none"> – One USB 3.0 port – Two SATA 3.0 ports <p>NOTE You are not advised to install the operating system on the USB storage media.</p>
Video card	<p>An SM750 video with 32 MB display memory is integrated on the BMC chip. The maximum display resolution is 1920 x 1200 at 60 Hz with 16 M colors.</p> <p>NOTE</p> <ul style="list-style-type: none"> • The integrated video card can provide the maximum display resolution (1920 x 1200) only after the video card driver matching the operating system version is installed. Otherwise, only the default resolution supported by the operating system is provided. • If both the front and rear VGA ports are connected to monitors, only the monitor connected to the front VGA port displays information.
System management	<ul style="list-style-type: none"> • UEFI • iBMC • NC-SI • Integration with third-party management systems
Security feature	<ul style="list-style-type: none"> • Power-on password • Administrator password • TCM (only in China)/TPM • Secure boot • Front bezel (optional) • Chassis cover opening detection

6.2 Environmental Specifications

Table 6-2 Environmental specifications

Category	Specifications
Temperature	<ul style="list-style-type: none"> • Operating temperature: 5°C to 45°C (41°F to 113°F) (ASHRAE Classes A1 to A4 compliant) • Storage temperature (within three months): –30°C to +60°C (–22°F to 140°F) • Storage temperature (within six months): –15°C to +45°C (5°F to 113°F) • Storage temperature (within one year): –10°C to +35°C (14°F to 95°F)

Category	Specifications
	<ul style="list-style-type: none"> Maximum rate of temperature change: 20°C (36°F) per hour, 5°C (9°F) per 15 minutes <p>NOTE The highest operating temperature varies depending on the server configuration. For details, see A.2 Operating Temperature Limitations .</p>
Relative humidity (RH, non-condensing)	<ul style="list-style-type: none"> Operating humidity: 8% to 90% Storage humidity (within three months): 8% to 85% Storage humidity (within six months): 8% to 80% Storage humidity (within one year): 20% to 75% Maximum humidity change rate: 20%/h
Air volume	≥ 196 cubic feet per minute (CFM)
Operating altitude	≤ 3050 m (10006.44 ft) <ul style="list-style-type: none"> When the server configuration complies with ASHRAE Classes A1 and A2 and the altitude is above 900 m (2952.76 ft), the highest operating temperature decreases by 1°C (1.8°F) for every increase of 300 m (984.24 ft). When the server configuration complies with ASHRAE Class A3 and the altitude is above 900 m (2952.76 ft), the highest operating temperature decreases by 1°C (1.8°F) for every increase of 175 m (574.14 ft). When the server configuration complies with ASHRAE Class A4 and the altitude is above 900 m (2952.76 ft), the highest operating temperature decreases by 1°C (1.8°F) for every increase of 125 m (410.1 ft). HDDs cannot be used at an altitude of over 3050 m (10006.44 ft).
Corrosive gaseous contaminant	Maximum corrosion product thickness growth rate: <ul style="list-style-type: none"> Copper corrosion rate test: 300 Å/month (meeting level G1 requirements of the ANSI/ISA-71.04-2013 standard on gaseous corrosion) Silver corrosion rate test: 200 Å/month
Particle contaminant	<ul style="list-style-type: none"> The equipment room environment meets the requirements of ISO 14664-1 Class 8. There is no explosive, conductive, magnetic, or corrosive dust in the equipment room. <p>NOTE It is recommended that the particulate pollutants in the equipment room be monitored by a professional organization.</p>
Acoustic noise	The declared A-weighted sound power levels (LWAd) and declared average bystander position A-weighted sound pressure levels (LpAm) listed are measured at 23°C (73.4°F) in accordance with ISO 7779 (ECMA 74) and declared in accordance with ISO 9296 (ECMA 109).

Category	Specifications
	<ul style="list-style-type: none"> • Idle: <ul style="list-style-type: none"> – LWAd: 6.69 Bels – LpAm: 49.0 dBA • Running: <ul style="list-style-type: none"> – LWAd: 6.74 Bels – LpAm: 49.4 dBA <p>NOTE Actual sound levels generated during server operation vary depending on server configuration, load, and ambient temperature.</p>

 **NOTE**

SSDs and HDDs (including NL-SAS, SAS, and SATA) cannot be preserved for a long time in the power-off state. Data may be lost or faults may occur if the preservation duration exceeds the specified maximum duration. When drives are preserved under the storage temperature and humidity specified in the preceding table, the following preservation time is recommended:

- Maximum preservation duration of SSDs:
 - 12 months in power-off state without data stored
 - 3 months in power-off state with data stored
- Maximum preservation duration of HDDs:
 - 6 months in unpacked/packed and powered-off state
- The maximum preservation duration is determined according to the preservation specifications provided by drive vendors. For details, see the manuals provided by drive vendors.

6.3 Physical Specifications

Table 6-3 Physical specifications

Category	Description
Dimensions (H x W x D)	86.1 mm x 447 mm x 790 mm (3.39 in. x 17.60 in. x 31.10 in.)
Installation space	<ul style="list-style-type: none"> • Requirements for cabinet installation: Cabinet compliant with the International Electrotechnical Commission (IEC) 297 standard <ul style="list-style-type: none"> – Cabinet width: 482.6 mm (19.00 in.) – Cabinet depth ≥ 1000 mm (39.37 in.) • Requirements for guide rail installation: <ul style="list-style-type: none"> – L-shaped guide rails: apply only to our company's cabinets. – Static rail kit: applies to cabinets with a distance of 543.5 mm to 848.5 mm (21.40 in. to 33.41 in.) between the front and rear mounting bars. – Ball bearing rail kit: applies to cabinets with a distance of 609 mm to 950 mm (23.98 in. to 37.40 in.) between

Category	Description
	the front and rear mounting bars.
Weight in full configuration	<ul style="list-style-type: none"> • Maximum net weight: <ul style="list-style-type: none"> – Server with 8 x 2.5" drives: 28.19 kg (62.16 lb) – Server with 12 x 2.5" drives: 28.52 kg (62.89 lb) – Server with 20 x 2.5" drives: 29.75 kg (65.60 lb) – Server with 24 x 2.5" drives: 32.07 kg (70.71 lb) – Server with 25 x 2.5" drives: 32.44 kg (71.53 lb) • Packaging materials: 5 kg (11.03 lb)
Power consumption	The power consumption parameters vary with hardware configurations (including the configurations complying with EU ErP). Use the Power Calculator to obtain specific information.

7 Software and Hardware Compatibility

Use the [Compatibility Checker](#) to obtain information about the operating systems and hardware supported.

NOTICE

- If incompatible components are used, the device may be abnormal. This fault is beyond the scope of technical support and warranty.
 - The performance of servers is closely related to application software, basic middleware software, and hardware. The slight differences of the application software, middleware basic software, and hardware may cause performance inconsistency between the application layer and test software layer.
 - If the customer has requirements on the performance of specific application software, contact technical support to apply for POC tests in the pre-sales phase to determine detailed software and hardware configurations.
 - If the customer has requirements on hardware performance consistency, specify the specific configuration requirements (for example, specific drive models, RAID controller cards, or firmware versions) in the pre-sales phase.
-

8 Safety Instructions

8.1 Security

8.2 Maintenance and Warranty

8.1 Security

General Statement

- Comply with local laws and regulations when installing devices. These Safety Instructions are only a supplement.
- The "DANGER", "WARNING", and "CAUTION" information in this document does not represent all the safety instructions, but supplements to the safety instructions.
- Observe all safety instructions provided on the device labels when installing hardware. Follow them in conjunction with these Safety Instructions.
- Only qualified personnel are allowed to perform special tasks, such as performing high-voltage operations and driving a forklift.
- This is a class A product, which may cause radio interference in a domestic environment. Take protective measures before operating this product in a residential environment.

Personal Safety

- Only personnel certified or authorized are allowed to install equipment.
- Discontinue any dangerous operations and take protective measures. Report anything that could cause personal injury or device damage to a project supervisor.
- Do not move devices or install racks and power cables in hazardous weather conditions.
- Do not carry the weight that is over the maximum load per person allowed by local laws or regulations. Before moving or installing equipment, check the maximum equipment weight and arrange required personnel.
- Wear clean protective gloves, ESD clothing, a protective hat, and protective shoes, as shown in Figure 8-1.

Figure 8-1 Safety work wear

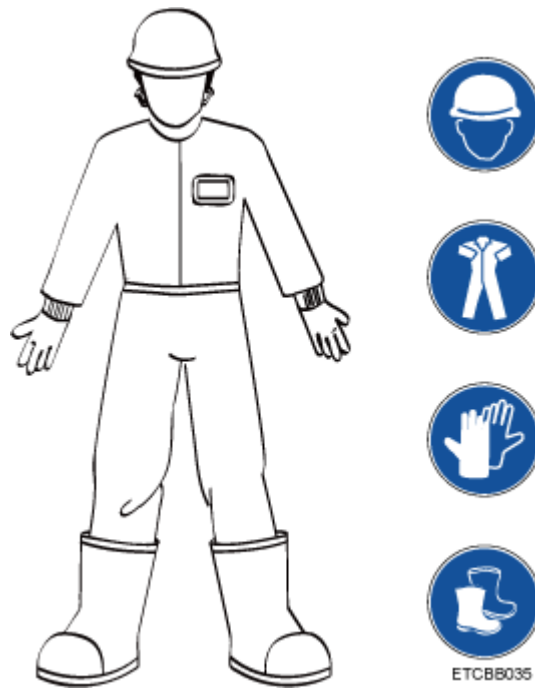

- Before touching a device, wear ESD clothing and gloves (or wrist strap), and remove any conductive objects (such as watches and jewelry). Figure 8-2 shows conductive objects that must be removed before you touch a device.

Figure 8-2 Removing conductive objects



Figure 8-3 shows how to wear an ESD wrist strap.

- Put your hands into the ESD wrist strap.
- Tighten the strap buckle and ensure that the ESD wrist strap is in contact with your skin.
- Insert the ground terminal attached to the ESD wrist strap into the jack on the grounded rack or chassis.

Figure 8-3 Wearing an ESD wrist strap

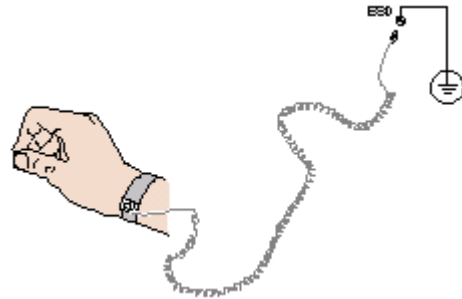

- Exercise caution when using tools.
- If the installation position of a device is higher than the shoulders of the installation personnel, use a vehicle such as a lift to facilitate installation. Prevent the device from falling down and causing personal injury or damage to the device.
- The equipment is powered by high-voltage power sources. Direct or indirect contact (especially through damp objects) with high-voltage power sources may result in serious injury or death.
- Ground the equipment before powering it on. Otherwise, personal injury may be caused by high electricity leakage.
- When a ladder is used, ensure that another person holds the ladder steady to prevent accidents.
- Do not look into optical ports without eye protection.

Device Security

- Use the recommended power cables at all times.
- Use power cables only for dedicated servers. Do not use them for other devices.
- Before operating equipment, wear ESD clothes and gloves to prevent electrostatic-sensitive devices from being damaged by ESD.
- When moving a device, hold the bottom of the device. Do not hold the handles of the installed modules, such as the PSUs, fan modules, drives, and the mainboard. Handle the equipment with care.
- Exercise caution when using tools.
- Connect the primary and secondary power cables to different power distribution units (PDUs) to ensure reliable system operation.
- Ground a device before powering it on. Otherwise, high leakage current may cause device damage.

Transportation Precautions

Improper transportation may damage equipment. Contact the manufacturer for precautions before attempting transportation.

Transportation precautions include but are not limited to:

- The logistics company engaged to transport the device must be reliable and comply with international standards for transporting electronics. Ensure that the equipment being transported is always kept upright. Take necessary precautions to prevent collisions, corrosion, package damage, damp conditions and pollution.

- Transport each device in its original packaging.
- If the original packaging is unavailable, package heavy, bulky parts (such as chassis and blades) and fragile parts (such as PCIe cards and optical modules) separately.

 **NOTE**

For details about the components supported by the server, see "Compatibility" in the [Compatibility Checker](#).

- Power off all devices before transportation.

Maximum Weight Carried by a Person

 **CAUTION**

Comply with local regulations for the maximum load per person.

Table 8-1 lists the maximum weight one person is permitted to carry as stipulated by a number of organizations.

Table 8-1 Maximum weight carried per person

Organization	Weight (kg/lb)
European Committee for Standardization (CEN)	25/55.13
International Organization for Standardization (ISO)	25/55.13
National Institute for Occupational Safety and Health (NIOSH)	23/50.72
Health and Safety Executive (HSE)	25/55.13
General Administration of Quality Supervision, Inspection and Quarantine of the People's Republic of China (AQSIQ)	<ul style="list-style-type: none"> • Male: 15/33.08 • Female: 10/22.05

For more information about safety instructions, see *Server Safety Information*.

8.2 Maintenance and Warranty

For details about the maintenance policy, visit [Customer Support Service](#).

For details about the warranty policy, visit [Warranty](#).

9 System Management

This product integrates the new-generation Intelligent Baseboard Management Controller (iBMC), which complies with Intelligent Platform Management Interface 2.0 (IPMI 2.0) specifications and provides reliable hardware monitoring and management.

The iBMC provides the following features:

- Various management interfaces
The iBMC provides the following standard interfaces to meet various system integration requirements:
 - DCMI 1.5 interface
 - IPMI 1.5/IPMI 2.0 interface
 - CLI
 - Redfish interface
 - HTTPS
 - SNMP
- Fault detection and alarm management
Faults can be detected and rectified in advance to ensure 24/7 stable running of the device.
 - The iBMC allows screenshots and videos to be created when the system breaks down, facilitating cause analysis of the system breakdown.
 - The iBMC offers screen snapshots and videos, simplifying routine preventive maintenance, recording, and auditing.
 - The FDM function supports component-based precise fault diagnosis, facilitating component fault locating and replacement.
 - The iBMC supports the reporting of alarms through syslog packets, trap packets, and emails, helping the upper-layer NMS to collect the fault information about the server.
- Security management
 - Software image backup improves system security. Even if the running software breaks down, the system can be started from the backup image.
 - Diversified user security control interfaces are provided to ensure user login security.
 - Multiple types of certificates can be imported and replaced to ensure data transmission security.

- System maintenance interface
 - The virtual KVM and virtual media functions facilitate remote maintenance.
 - The iBMC supports out-of-band RAID monitoring and configuration to improve RAID configuration efficiency and management capabilities.
 - Smart Provisioning provides a convenient operation interface for installing the OS, configuring RAID, and performing the upgrade without a CD-ROM.
- Various network protocols
 - The NTP synchronizes network time to optimize time configuration.
 - The iBMC supports domain name system (DNS) and Lightweight Directory Application Protocol (LDAP) to implement domain management and directory service.
- Intelligent power management
 - The power capping technology helps you easily improve deployment density.
 - The iBMC uses dynamic power saving to reduce operational expenditure (OPEX).
- License management

By managing licenses, you can use the features of the iBMC advanced edition in authorization mode.

Compared with the standard edition, the iBMC advanced edition provides more advanced features, such as:

 - Implements the OS deployment using Redfish.
 - Collect the original data of intelligent diagnosis using Redfish.

A Appendix

A.1 Product SN

The serial number (SN) on the slide-out label plate uniquely identifies a device. The SN is required when you contact technical support.

Figure A-1 SN example

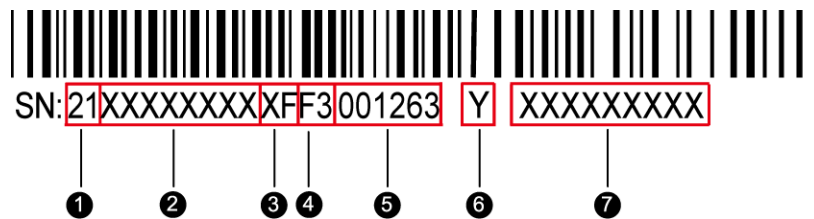

Table A-1 SN description

No.	Description
1	ESN ID (two characters), which can only be 21.
2	Material ID (eight characters), that is, the processing code.
3	Vendor code (two characters), that is, the code of the processing place.
4	<p>Year and month (two characters).</p> <ul style="list-style-type: none"> The first character indicates the year. <ul style="list-style-type: none"> Digits 1 to 9 indicate years 2001 to 2009, respectively. Letters A to H indicate years 2010 to 2017, respectively. Letters J to N indicate years 2018 to 2022, respectively. Letters P to Y indicate years 2023 to 2032, respectively. <p>NOTE</p> <p>The years from 2010 are represented by upper-case letters excluding I, O, and Z because the three letters are similar to the digits 1, 0, and 2.</p> <ul style="list-style-type: none"> The second character indicates the month. <ul style="list-style-type: none"> Digits 1 to 9 indicate January to September, respectively.

No.	Description
	- Letters A to C indicate October to December, respectively.
5	Serial number (six digits).
6	RoHS compliance (one character). Y indicates RoHS compliant.
7	Internal model, that is, product name.

A.2 Operating Temperature Limitations

Table A-2 Operating temperature limitations

Configuration	Max. 30°C (86°F)	Max. 35°C (95°F)	Max. 40°C (104°F)	Max. 45°C (113°F)
8 x 2.5" drive pass-through configuration (8 x SAS/SATA)	<ul style="list-style-type: none"> All options supported^a 	Options supported: <ul style="list-style-type: none"> Processors of up to 250 W^b 100GE PCIe NICs^c 100GE IB cards^c 	Options supported: <ul style="list-style-type: none"> Processors of up to 165 W Options not supported: <ul style="list-style-type: none"> GPU cards BPS and 256 GB memory 10GE/25GE/100GE OCP 3.0 network adapters 100GE PCIe NICs 100GE IB cards 	Options supported: <ul style="list-style-type: none"> Processors of up to 165 W Up to twenty-four 64 GB DDR4 memory modules Up to two 10GE NICs Options not supported: <ul style="list-style-type: none"> GPU cards 10GE/25GE/100GE OCP 3.0 network adapters
12 x 2.5" drive pass-through configuration (4 x SAS/SATA + 8 x NVMe)	<ul style="list-style-type: none"> All options supported^a 	Options supported: <ul style="list-style-type: none"> Processors of up to 250 W^b 100GE PCIe NICs^c 100GE IB cards^c 	Options supported: <ul style="list-style-type: none"> Processors of up to 165 W Options not supported: <ul style="list-style-type: none"> GPU cards BPS and 256 GB memory 	<ul style="list-style-type: none"> Not supported

Configuration	Max. 30°C (86°F)	Max. 35°C (95°F)	Max. 40°C (104°F)	Max. 45°C (113°F)
			<ul style="list-style-type: none"> • 10GE/25GE /100GE OCP 3.0 network adapters • 100GE PCIe NICs • 100GE IB cards 	
20 x 2.5" drive pass-through configuration (4 x SAS/SATA + 16 x NVMe)	Options supported: <ul style="list-style-type: none"> • Processors of up to 250 W (except the 8356H processors) Options not supported: <ul style="list-style-type: none"> • GPU cards 	Options supported: <ul style="list-style-type: none"> • Processors of up to 205 W (except the 8356H processors) • 100GE OCP 3.0 network adapters^c • 100GE PCIe NICs^c • 100GE IB cards^c Options not supported: <ul style="list-style-type: none"> • GPU cards 	<ul style="list-style-type: none"> • Not supported 	<ul style="list-style-type: none"> • Not supported
24 x 2.5" drive pass-through configuration (24 x SAS/SATA)	Options supported: <ul style="list-style-type: none"> • Processors of up to 250 W (except the 8356H processors) Options not supported: <ul style="list-style-type: none"> • GPU cards 	Options supported: <ul style="list-style-type: none"> • Processors of up to 205 W (except the 8356H processors) • 100GE OCP 3.0 network adapters^c • 100GE PCIe NICs^c • 100GE IB cards^c Options not supported: <ul style="list-style-type: none"> • GPU cards 	<ul style="list-style-type: none"> • Not supported 	<ul style="list-style-type: none"> • Not supported
25 x 2.5" drive EXP	Options supported:	Options supported:	<ul style="list-style-type: none"> • Not supported 	<ul style="list-style-type: none"> • Not supported

Configuration	Max. 30°C (86°F)	Max. 35°C (95°F)	Max. 40°C (104°F)	Max. 45°C (113°F)
configuration (25 x SAS/SATA)	<ul style="list-style-type: none"> Processors of up to 250 W (except the 8356H processors) Options not supported: <ul style="list-style-type: none"> GPU cards 	<ul style="list-style-type: none"> Processors of up to 205 W (except the 8356H processors) 100GE OCP 3.0 network adapters^c 100GE PCIe NICs^c 100GE IB cards^c Options not supported: <ul style="list-style-type: none"> GPU cards 		
<ul style="list-style-type: none"> a: When two full-length or four half-length GPU cards are configured, processors of up to 165 W are supported. b: Full-length GPU cards are not supported. When two half-length GPU cards are configured, processors of up to 165 W are supported. c: When processors of 165 W or lower are configured, the highest operating temperature is 35°C (95°F). When processors of 165 W or higher are configured, the highest operating temperature is 30°C (86°F). When a single fan is faulty: <ul style="list-style-type: none"> The maximum operating temperature is 5°C (9°F) lower than the rated value. When 10GE/25GE/100GE OCP 3.0 network adapters and processors of 225 W or higher are used, the NIC performance may be affected. You are advised to replace the fan module as soon as possible. 				

A.3 Nameplate

Certified Model	Usage Restrictions
H24H-06	Global

A.4 RAS Features

The server supports a variety of Reliability, Availability, and Serviceability (RAS) features. You can configure these features for better performance.

For details about the RAS features, see *FusionServer 2488H V6 Server RAS Technical White Paper*.

A.5 Sensor List

Sensor	Description	Component
Inlet Temp	Air inlet temperature	Left mounting ear
Outlet Temp	Air outlet temperature	Component in position U2030 on the mainboard
PCH Temp	PCH bridge temperature	Component in position U240 on the mainboard
CPUN Core Rem	CPU core temperature	CPU. <i>N</i> indicates the CPU number. The value ranges from 1 to 4 .
CPUN DTS	CPU DTS value	
Cpu <i>N</i> Margin	CPUN Margin temperature	
CPUN Prochot	CPU Prochot	
CPUN VDDQ Temp	CPU VDDQ temperature	CPU 1: components in positions U149 and U154 on the mainboard CPU 2: components in positions U159 and U164 on the mainboard CPU 3: components in positions U169 and U174 on the mainboard CPU 4: components in positions U184 and U179 on the mainboard <i>N</i> indicates the CPU number. The value ranges from 1 to 4 .
CPUN VRD Temp	CPU VRD temperature	CPU 1: component in position U51 on the mainboard CPU 2: component in position U134 on the mainboard CPU 3: component in position U52 on the mainboard CPU 4: component in position U53 on the mainboard <i>N</i> indicates the CPU number. The value ranges from 1 to 4 .
CPUN MEM Temp	CPU DIMM temperature	DIMMs of CPUN. <i>N</i> indicates the CPU number.

Sensor	Description	Component
		The value ranges from 1 to 4 .
SSD Disk <i>N</i> Temp	SSD temperature	SSD. <i>N</i> indicates the physical drive slot number.
FAN <i>N</i> F Speed	Fan speed	Fan module. <i>N</i> indicates the fan module number. The value ranges from 1 to 6 .
FAN <i>N</i> R Speed		
Power	Server input power	Total PSU power
Power <i>N</i>	PSU input power	PSU. <i>N</i> indicates the PSU number. The value is 1 or 2 .
CPUN Status	CPU status	CPU. <i>N</i> indicates the CPU number. The value ranges from 1 to 4 .
CPUN Memory	DIMM status	DIMMs of CPU <i>N</i> . <i>N</i> indicates the CPU number. The value ranges from 1 to 4 .
CPU1 VccIn Temp	CPU 1 VCCIN temperature	Component in position U2038 on the mainboard
CPU2 VccIn Temp	CPU 2 VCCIN temperature	Component in position U2039 on the mainboard
Disks Temp	Maximum temperature of SAS/SATA drives	Drive
1711 Core Temp	Core temperature of the BMC management chip	Component in position U94 on the mainboard
PSN Fan Status	PSU fan fault status	PSU. <i>N</i> indicates the PSU number. The value is 1 or 2 .
PSN Temp Status	PSU presence	
PSN Status	PSU status	
Power Button	Power button pressed	Left mounting ear
UID Button	UID button status	Left mounting ear
AreaIntrusion	Chassis cover status	Chassis cover
DISK <i>N</i>	Disk status	Drive. <i>N</i> indicates the physical drive slot number.
FAN <i>N</i> F Presence	Fan presence	Fan module. <i>N</i> indicates the fan module number. The value ranges from 1 to 6 .
FAN <i>N</i> R Presence		
FAN <i>N</i> F Status	Fan fault status	
FAN <i>N</i> R Status		

Sensor	Description	Component
RTC Battery	RTC battery status. An alarm is generated when the voltage is lower than 1 V.	CMOS battery
DIMM <i>N</i>	DIMM status	DIMM. <i>N</i> indicates the DIMM slot number.
PCH Status	PCH chip fault diagnosis health status	Component in position U240 on the mainboard
LCD Presence	LCD presence	LCD
LCD Status	LCD health status	
PS Redundancy	Redundancy failure due to PSU removal	PSU. <i>N</i> indicates the PSU number. The value is 1 or 2 .
PS <i>N</i> Inlet Temp	PSU air inlet temperature	
Riser <i>N</i> Temp	Riser card temperature	Riser card. <i>N</i> indicates the riser card number. The value is 1 or 2 .
SYS 3.3V_1	Mainboard 3.3 V voltage	N/A. <i>N</i> indicates the component number.
SYS 3.3V_2	Mainboard 3.3 V voltage	
SYS 5V	Mainboard 5.0 V voltage	
SYS 12V_1	Mainboard 12.0 V voltage (the first output 12 V voltage detection for soft-start (CPU 1 + VCC_5V))	
SYS 12V_2	Mainboard 12.0 V voltage (the second output 12 V voltage detection for soft-start (CPU 2))	
SYS 12V_3	Mainboard 12.0 V voltage (the third output 12 V voltage detection for soft-start (CPU 3))	
SYS 12V_4	Mainboard 12.0 V voltage (the fourth output 12 V voltage detection for soft-start (CPU 4))	
SYS 12V_5	Mainboard 12.0 V voltage (the fifth output 12 V voltage detection for soft-start (drive backplane + slot 10))	
SYS 12V_6	Mainboard 12.0 V voltage	

Sensor	Description	Component
	(the sixth output 12 V voltage detection for soft-start (riser 1 + slots 4/5/6))	
SYS 12V_7	Mainboard 12.0 V voltage (the seventh output 12 V voltage detection for soft-start (riser 2 + VCC_3V3 + USB_VCC_5V))	
SYS 12V_8	Mainboard 12.0 V voltage (the eighth output 12 V voltage detection for soft-start (fan module))	
Standby 5V	Mainboard standby 5.0 V voltage	
CPUN DDR VDDQ	CPU DIMM voltage	
CPUN DDR VDDQ2		
CPUN VSA	CPU VSA voltage	
CPUN VCCIO	CPU VCCIO voltage	
CPUN VCCIN	CPU VCCIN voltage	
PwrOk Sig. Drop	Voltage dip status	
ACPI State	ACPI status	
SysFWProgress	Software process and system startup errors	
SysRestart	Cause of system restart	
Boot Error	Boot error	
Watchdog2	Watchdog	
Mngmnt Health	Management subsystem health status	
RiserN Card	Hardware presence	
SAS Cable	Hardware presence	
PCIe RAIDN Temp	Temperature of the RAID controller card	
OCPN Temp	OCP NIC temperature	
OCPN OP Temp	OCP optical module temperature	
M2 Temp(PCIeN)	Maximum temperature of all	

Sensor	Description	Component
	M.2 drives of the RAID controller card	
PCIe Status	PCIe status error	
PwrOn TimeOut	Power-on timeout	
PwrCap Status	Power capping status	
NIC1 Presence	NIC 1 presence	
HDD Backplane	Drive backplane entity presence	
HDD BP Status	Drive backplane health status	
PortN Link Down (N 1. 2. 3. 4)	Network port link status	
CPUN UPI Link (N 1. 2. 3.4)	CPU UPI link fault diagnosis health status	
System Notice	Hot restart reminder and fault diagnosis program information collection	
System Error	System suspension or restart. Check the background logs.	
BMC Boot Up	BMC startup events	
SEL Status	SEL full or clearing events	
Op. Log Full	Operation log full or clearing events	
Sec. Log Full	Security log full or clearing events	
CPU Usage	CPU usage	
Memory Usage	Memory usage	
PCIeN Card BBU	BBU fault or low voltage on a PCIe card	
BMC Time Hopping	Time hopping	
NTP Sync Failed	NTP synchronization failure and recovery events	
Host Loss	System monitoring software (BMA) link loss detection	
GPUN Temp	GPU temperature	

Sensor	Description	Component
PCIeN Inlet Temp	PCIe smart card air inlet temperature	
PCIeN Cpu Temp	PCIe smart card CPU temperature	
PCIeN OP Temp	PCIe card optical module temperature	
PCIeN NIC Temp	PCIe card chip temperature	
PSN VIN	Input voltage	

B Glossary

B.1 A-E

B

BMC	The baseboard management controller (BMC) complies with the Intelligent Platform Management Interface (IPMI). It collects, processes, and stores sensor signals, and monitors the operating status of components. The BMC provides the hardware status and alarm information about the managed objects to the upper-level management system, so that the management system can manage the objects.
------------	--

E

ejector lever	A part on the panel of a device used to facilitate installation or removal of the device.
Ethernet	A baseband local area network (LAN) architecture developed by Xerox Corporation by partnering with Intel and DEC. Ethernet uses the Carrier Sense Multiple Access/Collision Detection (CSMA/CD) access method and allows data transfer over various cables at 10 Mbit/s. The Ethernet specification is the basis for the IEEE 802.3 standard.

B.2 F-J

G

Gigabit Ethernet (GE)	An extension and enhancement of traditional shared media Ethernet standards. It is compatible with 10 Mbit/s and 100 Mbit/s Ethernet and complies with IEEE 802.3z standards.
------------------------------	---

H

hot swap	Replacing or adding components without stopping or shutting down the system.
-----------------	--

B.3 K-O

K

KVM	A hardware device that provides public video, keyboard and mouse (KVM).
------------	---

B.4 P-T

P

panel	An external component (including but not limited to ejector levers, indicators, and ports) on the front or rear of the server. It seals the front and rear of the chassis to ensure optimal ventilation and electromagnetic compatibility (EMC).
Peripheral Component Interconnect Express (PCIe)	A computer bus PCI, which uses the existing PCI programming concepts and communication standards, but builds a faster serial communication system. Intel is the main sponsor for PCIe. PCIe is used only for internal interconnection. A PCI system can be transformed to a PCIe system by modifying the physical layer instead of software. PCIe delivers a faster speed and can replace almost all AGP and PCI buses.

R

redundancy	A mechanism that allows a backup device to automatically take over services from a faulty device to ensure uninterrupted running of the system.
redundant array of independent disks (RAID)	A storage technology that combines multiple physical drives into a logical unit for the purposes of data redundancy and performance improvement.

S

server	A special computer that provides services for clients over a network.
---------------	---

system event log (SEL)	Event records stored in the system used for subsequent fault diagnosis and system recovery.
-------------------------------	---

B.5 U-Z

U

U	A unit defined in International Electrotechnical Commission (IEC) 60297-1 to measure the height of a cabinet, chassis, or subrack. 1 U = 44.45 mm
UltraPath Interconnect (UPI)	A point-to-point processor interconnect developed by Intel.

C Acronyms and Abbreviations

C.1 A-E

A

AC	alternating current
AES	Advanced Encryption Standard New Instruction Set
ARP	Address Resolution Protocol
AVX	Advanced Vector Extensions

B

BBU	backup battery unit
BIOS	Basic Input/Output System
BMC	baseboard management controller

C

CCC	China Compulsory Certification
CD	calendar day
CE	Conformite Europeenne
CIM	Common Information Model
CLI	command-line interface

D

DC	direct current
DDR4	Double Data Rate 4
DDDC	double device data correction
DEMT	Dynamic Energy Management Technology
DIMM	dual in-line memory module
DRAM	dynamic random-access memory
DVD	digital video disc

E

ECC	error checking and correcting
ECMA	European Computer Manufacturer Association
EDB	Execute Disable Bit
EN	European Efficiency
ERP	enterprise resource planning
ETS	European Telecommunication Standards

C.2 F-J

F

FB-DIMM	Fully Buffered DIMM
FC	Fiber Channel
FCC	Federal Communications Commission
FCoE	Fibre Channel over Ethernet
FTP	File Transfer Protocol

G

GE	Gigabit Ethernet
GPIO	General Purpose Input/Output
GPU	graphics processing unit

H

HA	high availability
HDD	hard disk drive
HPC	high-performance computing
HTTP	Hypertext Transfer Protocol
HTTPS	Hypertext Transfer Protocol Secure

I

iBMC	intelligent baseboard management controller
IC	Industry Canada
ICMP	Internet Control Message Protocol
IDC	Internet Data Center
IEC	International Electrotechnical Commission
IEEE	Institute of Electrical and Electronics Engineers
IGMP	Internet Group Message Protocol
IOPS	input/output operations per second
IP	Internet Protocol
IPC	Intelligent Power Capability
IPMB	Intelligent Platform Management Bus
IPMI	Intelligent Platform Management Interface

C.3 K-O

K

KVM	keyboard, video, and mouse
------------	----------------------------

L

LC	Lucent Connector
-----------	------------------

LRDIMM	load-reduced dual in-line memory module
LED	light emitting diode
LOM	LAN on motherboard

M

MAC	media access control
MMC	module management controller

N

NBD	next business day
NC-SI	Network Controller Sideband Interface

O

OCP	Open Compute Project
------------	----------------------

C.4 P-T

P

PCIe	Peripheral Component Interconnect Express
PDU	power distribution unit
PHY	physical layer
PMBUS	power management bus
POK	Power OK
PWM	pulse-width modulation
PXE	Preboot Execution Environment

R

RAID	redundant array of independent disks
-------------	--------------------------------------

RAS	reliability, availability and serviceability
RDIMM	registered dual in-line memory module
REACH	Registration Evaluation and Authorization of Chemicals
RJ45	registered jack 45
RoHS	Restriction of the Use of Certain Hazardous Substances in Electrical and Electronic Equipment

S

SAS	Serial Attached Small Computer System Interface
SATA	Serial Advanced Technology Attachment
SCM	supply chain management
SDDC	single device data correction
SERDES	serializer/deserializer
SGMII	serial gigabit media independent interface
SMI	serial management interface
SMTP	Simple Mail Transfer Protocol
SNMP	Simple Network Management Protocol
SOL	serial over LAN
SONCAP	Standards Organization of Nigeria-Conformity Assessment Program
SSD	solid-state drive
SSE	Streaming SIMD Extension

T

TACH	tachometer signal
TBT	Turbo Boost Technology
TCG	Trusted Computing Group
TCM	trusted cryptography module
TCO	total cost of ownership
TDP	thermal design power
TELNET	Telecommunication Network Protocol

TET	Trusted Execution Technology
TFM	TransFlash module
TFTP	Trivial File Transfer Protocol
TOE	TCP offload engine
TPM	trusted platform module

C.5 U-Z

U

UDIMM	unbuffered dual in-line memory module
UEFI	Unified Extensible Firmware Interface
UID	unit identification light
UL	Underwriter Laboratories Inc.
UPI	UltraPath Interconnect
USB	Universal Serial Bus

V

VCCI	Voluntary Control Council for Interference by Information Technology Equipment
VGA	Video Graphics Array
VLAN	virtual local area network
VRD	voltage regulator-down

W

WEEE	waste electrical and electronic equipment
WSMAN	Web Service Management