

Overview

HPE Edgeline EL8000t Converged Edge System

HPE Edgeline EL8000t Converged Edge System delivers data-intensive, low-latency compute based on open standards and advanced remote manageability. Designed to enable communication service providers (CSPs) to capitalize on data-intensive, low-latency services for media delivery, connected mobility, and smart cities, the HPE Edgeline EL800t Converged Edge System can process vast amounts of data in real time directly at the edge, based on open standards to boost flexibility and reduce costs.

To deliver new services that tap into the massive growth of real-time data, CSPs must transform their telecommunications network edge towards standard IT systems and software-defined architectures, such as virtual radio access networks (vRAN) and virtual cable modem termination systems (vCMTS). The open-standards based HPE Edgeline EL8000t Converged Edge System provides a cost effective replacement for proprietary edge systems, with enhanced performance and versatility for data-intensive real-time digital services.

Additionally, the unique design of the HPE Edgeline EL8000t Converged Edge System delivers high performance and ultra-low latency for the most demanding use cases, including media streaming, IoT, artificial intelligence, and video analytics in a compact and ruggedized form factor, equipped with edge-optimized serviceability and remote systems management. It shortens the time taken to make an enterprise IT system ready for deployment, provides access at the edge to the same applications used in the core and consequently accelerates the agility of defense, law enforcement and civilian agencies.

The compact and rugged design of the HPE Edgeline EL8000t Converged Edge System allows deployment of traditional datacenter software applications in hostile Edge environments.

Exceeding the requirements of industry standards NEBS Level 3 and ASHRAE class 3 and 4, the system is resistant to hazardous environmental influences such as heat, shock and vibration, as well as failure, supporting continuous operation between 0 and 55 degrees Celsius. The system can run rack mounted or stand-alone in any space available, with either a front-to-back or back-to-front cooling design.

The single-socket design of companion e910t blades, equipped with high-end Intel® Xeon® Scalable Processors, reduces latency and energy consumption. System components can be combined, scaled and hot-swapped to meet changing demands, with robust support for accelerators from a variety of vendors. With a range of depth and width options for blades and chassis, the system can be flexibly configured and scaled to meet new or changing use-case requirements.

Proven HPE iLO 5 technology enables remote provisioning, ongoing system health monitoring, updates, management and security of servers installed in a HPE Edgeline EL8000t Converged Edge Systems from cell towers to oil rigs, without needing IT expertise on site.

Overview

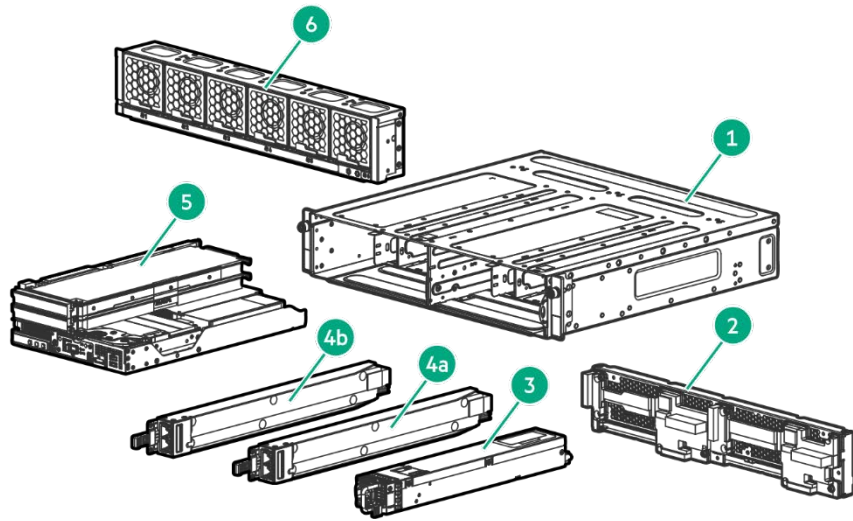

HPE Edgeline EL8000t 2U Front Cabling Chassis View

Item	Description	Item	Description
1	Edgeline EL8000t System	4b	EL8000t Chassis Controller + Network Module (Left Bay)
2	Edgeline EL8000t backplane assembly	5	HPE ProLiant e910t Server Blade (1 or 2 per system)
3	Power supply	6	Fan Assembly
4a	Network Module (Right Bay)		



Standard Features

Enclosure

The HPE Edgeline EL8000t Chassis supports the following ProLiant Server Blade configuration

- **Server Blade Configurations**
ProLiant e910t 2U Blade Server
- **EL8000t 2U Front Cabling Chassis**
Min: 1, Max: 2

HPE ProLiant Server Blades

HPE Edgeline EL8000t System supports:

- HPE ProLiant e910t 2U Server Blades

Notes:

- Please visit the ProLiant e910t Quickspecs at the following URL for detailed information and configuration possibilities
<https://www.hpe.com/h20195/v2/GetDocument.aspx?docname=a00073756enw>
- Blades supported on the Edgeline EL8000 system will not fit in an Edgeline EL8000t, and vice versa

HPE EL8000t Systems Power Supply

The HPE Edgeline EL8000t Systems supports redundant hot-plug power supplies.

Min: 1, Max: 2

HPE Edgeline EL8000 Front Cabling Chassis 1500W 264VAC Power Supply Kit

HPE Edgeline EL8000 Front Cabling Chassis 1500W -48VDC Power Supply Kit

Notes: Mixing of AC and DC power supply options in a chassis is allowed

Embedded Management

The HPE ProLiant Blade Servers plugged into an HPE Edgeline EL8000t has its own iLO 5 management processor, which can be accessed directly through the management network port on the blades respective Network module.

The HPE Edgeline EL8000t System has an Edgeline Chassis Controller Module to monitor and control common chassis elements. The iLO 5 on the server blade communicates with the Edgeline Chassis Controller to gather and report status information on the chassis itself. The chassis controller cannot be directly accessed by the user.

Monitor your servers for ongoing management, service alerting, reporting and remote management with HPE iLO.

Learn more at <http://www.hpe.com/info/ilo>.

HPE Edgeline Component Pack

The HPE Edgeline Component Pack, is the delivery mechanism for firmware updates on the HPE Edgeline System. Before using your system for the first time, verify that you have the latest drivers, firmware, and system software installed. Update your system with the Edgeline Component Pack.

For more information, see the Edgeline Component Pack Update Guide on the Hewlett Packard Enterprise website:

<http://www.hpe.com/info/edgeline-docs>



Services and Support

Achieve maximum return from your IT investment

Get the expertise you need at every step of your IT journey with **HPE Pointnext services and support**. We help you lower your risks and costs using proven best practices, automation and methodologies that have been tested and refined by Hewlett Packard Enterprise experts through thousands of deployments globally. With **Advisory Services**, we focus on your business outcomes and goals, partnering with you to design your transformation and build a roadmap tuned to your unique challenges. Our **Professional** and **Operational Services** can be leveraged to speed up time-to-production, boost performance and accelerate your business. HPE Pointnext specializes in flawless and on-time implementation, on-budget execution, and creative configurations that get the most out of software and hardware alike.

Consume IT on your terms

HPE GreenLake Flex Capacity combines the simplicity, agility, and economics of public cloud with the security and performance benefits of on-premises IT. You determine your own “Right Mix” of Hybrid IT and workload placement without having to use. With its agile pay-per-use service, HPE GreenLake Flex Capacity can help your IT organization:

- Avoid IT expenses stemming from overprovisioning
- Improve time to market by maintaining a safe buffer of capacity, ready for use when you need it
- Keep capacity ahead of demand with regular monitoring—and a simple change order to replenish
- Pay for only the capacity used, not the capacity deployed
- Reduce IT risk with tailored support

Connect your devices

Unlock all of the benefits of your technology investment by connecting your products to Hewlett Packard Enterprise. Reduce down time, increase diagnostic accuracy and have a single consolidated view of your environment. By connecting, you will receive 24x7 monitoring, pre-failure alerts, automatic call logging, and automatic parts dispatch. HPE Proactive Care Service and HPE Datacenter Care Service customers will also benefit from proactive activities to help prevent issues and increase optimization. All of these benefits are already available to you with your server storage and networking products, securely connected to HPE support. Learn more about getting connected at <http://www.hpe.com/services/getconnected>

Free up resources with Operational Services from HPE Pointnext

Choose from the recommended services for customers purchasing from Hewlett Packard Enterprise or an authorized reseller are quoted using Hewlett Packard Enterprise order configuration tools.

HPE Datacenter Care

Helps customers to address the pressing needs of IT today and smoothly transform to a more agile cloud-like IT operations model. We help run and monitor your IT by offloading the day to day routine tasks, helping customers be more predictive and proactive, and saving time with one place to call with for all of their IT. Datacenter Care is available as both tailored statement of work and as a packaged service for 3, 4, and 5 year terms.

Partner with an assigned account team backed by local and global experts, access HPE enhanced call experience with priority access, use specialized support for complex, technologies, choose hardware and software support for your devices, implement proactive monitoring to stay ahead of issues, and access HPE IT best practices and IP. HPE Datacenter Care advantage options are available to add to your agreement to give you specialized expertise for performance, security, back up analysis, and much more.

HPE Proactive Care

Gives customers an enhanced call experience. When your products are connected to HPE, Proactive Care helps prevent problems and maintains IT stability by utilizing personalized proactive reports with recommendations and advice.

HPE Proactive Care is available in 3, 4 and 5 year terms with a choice of response levels: Next Business day (NBD), 24x7 with a 4 hour response, and 24x7 with 6 hour call to repair (CTR). This Service combines both reactive support when there is a problem with an enhanced call experience and start to finish case management with proactive reporting and advice. This service also includes collaborative software support for Independent Software Vendors (ISVs), (Red Hat, VMWare, Microsoft, etc.).

<https://www.hpe.com/h20195/v2/GetPDF.aspx/4AA3-8855ENW.pdf>



Services and Support

HPE Proactive Care Advanced

HPE Proactive Care Advanced incorporates all the deliverables of HPE Proactive Care *plus* includes personalized support from a local, assigned Account Support Manager who will share best practice advice and personalized recommendations designed to help improve availability and performance to help increase stability and reduce unplanned downtime. Leverage your system's ability to connect to HPE for pre-failure alerts, automatic call logging and parts dispatch. For business critical incidents, Proactive Care Advanced offers critical event management to help reduce mean time to resolution. HPE Service Credits are included to redeem for technical and operational services. HPE Proactive Care Advanced is offered in 3, 4, and 5 year terms with a choice of response levels: Next Business day (NBD), 24x7 with a 4 hour response, and 24x7 with 6 hour call to repair (CTR).

<https://www.hpe.com/h20195/v2/getdocument.aspx?docname=4AA5-3259ENW>

HPE Foundation Care – (choose the response level that meets your needs)

HPE Foundation Care helps when there is a problem and is available in 3, 4, and 5 year terms with a choice of response levels: Next Business day (NBD), 24x7 with a 4 hour response, and 24x7 with 6 hour call to repair (CTR). Note that Call-To-Repair Service connects you to HPE 24 hours a day, seven days a week for assistance on resolving issues -this includes our highest level commitment to repair hardware within six hours after opening your case and respond to software questions within two hours. In addition, Collaborative software support is included and provides troubleshooting assistance on industry leading software running on your server. Simplify your support experience and make Hewlett Packard Enterprise your first call to help resolve hardware or software problems.

<https://www.hpe.com/h20195/V2/GetDocument.aspx?docname=4AA4-8876ENW&cc=us&lc=en>

Other related services from HPE Pointnext

Defective Media Retention

Is an option available with HPE Datacenter Care, HPE Proactive Care, Proactive Care Advanced, and HPE Foundation Care and applies only to Disk or eligible SSD/Flash Drives replaced by Hewlett Packard Enterprise due to malfunction.

HPE Server Hardware Installation

Provides for the basic hardware installation of your new Edgeline System. It is part of a suite of HPE deployment services that are designed to give you the peace of mind that comes from knowing your HPE products have been installed by an Hewlett Packard Enterprise authorized service specialist in accordance with the product's documentation.

<https://www.hpe.com/h20195/v2/Getdocument.aspx?docname=a00062322enw>

HPE Installation and Startup Service

Provides for the installation of your new Edgeline System. This service will assist you in bringing your new HPE Edgeline System into operation and make it remotely accessible in a timely and professional manner. The HPE service delivery technician will connect the product to the network as appropriate and enable remote support to allow for automatic case creation for hardware failures. Installation and start up services also includes the installation of one supported operating system type (Windows® or Linux).

<https://www.hpe.com/h20195/v2/Getdocument.aspx?docname=a00062211enw>

HPE Service Credits

Offers flexible services and technical skills to meet your IT demands as your business evolves. With a menu of services, you can access additional resources and specialist skills to help you maintain peak performance of your IT. HPE Service Credits help you proactively respond to your dynamic IT and business needs.

HPE Education Services

Provides comprehensive training designed to expand the skills of your IT staff and keep them up to speed with the latest technologies.

Consult your HPE Sales Representative or Authorized Channel Partner of choice for any additional questions and support options.



Services and Support

Warranty

This product is covered by a global limited warranty and supported by Hewlett Packard Enterprise Services and a worldwide network of Hewlett Packard Enterprise Authorized Partner Ready Resellers. Hardware diagnostic support and repair is available for three years from date of purchase. Support for initial setup is available for 90 days from date of purchase. Enhancements to the warranty services are available through HPE services or customized service agreements. Hard drives have either a one year or three-year warranty; refer to the specific hard drive QuickSpecs for details.

Notes: Chassis Warranty includes 3-Year Parts, 3-Year Labor, 3-Year Onsite support with next business day response. Warranty repairs may be accomplished through the use of Customer Self Repair (CSR) parts. These parts fall into two categories: 1) Optional CSR parts are designed for easy replacement but may involve added complexity. Customers may choose to have Hewlett Packard Enterprise replace Optional CSR parts at no charge. 2) No CSR parts require a Hewlett Packard Enterprise authorized service provider to replace the part. Additional information regarding worldwide limited warranty and technical support is available at: <http://h17007.www1.hpe.com/us/en/enterprise/servers/warranty/>

Parts and Materials

Hewlett Packard Enterprise will provide HPE-supported replacement parts and materials necessary to maintain the covered hardware product in operating condition, including parts and materials for available and recommended engineering improvements.

Parts and components that have reached their maximum supported lifetime and/or the maximum usage limitations as set forth in the manufacturer's operating manual, product quick-specs, or the technical product data sheet will not be provided, repaired, or replaced as part of these services.

The defective media retention service feature option applies only to Disk or eligible SSD/Flash Drives replaced by Hewlett Packard Enterprise due to malfunction.



Configuration Information

This section lists some of the steps required to configure a Factory Integrated Model. To ensure only valid configurations are ordered, Hewlett Packard Enterprise recommends the use of a Hewlett Packard Enterprise approved configurator. Contact your local sales representative for information on configurable product offerings and requirements.

Factory Integrated Models must start with an HPE Edgeline EL8000t System with the following minimum configuration:

- One (1) HPE ProLiant e910t Blade Server. Link to e910t quickspecs here:
<https://h20195.www2.hpe.com/v2/getdocument.aspx?docname=a00067735enw>
- One (1) HPE Edgeline EL8000 Power Supply

Step 1: Base Configuration (Choose System)

HPE Edgeline System

HPE Edgeline EL8000t 2U Configure-to-order Front Cabling Chassis

P27063-B21

Edgeline Chassis Controller Kit

P27143-B21

Notes: One ECM is required for chassis management of the EL8000t. This kit must be placed in the left hand bay

Step 2: Power Supply

Power Supplies

HPE Flex Slot Power Supplies (Min:1, Max:2)

HPE Edgeline EL8000 1500W 264VAC Front Cabling Power Supply Kit

P11290-B21

HPE Edgeline EL8000 1500W -48VDC Front Cabling Power Supply Kit

P11291-B21

Notes:

- Functional systems require at least 1 power supply to be configured, with 2 power supplies recommended for redundancy
- Mixing of AC (P11290-B21) and DC (P11291-B21) power supplies in a chassis is allowed
- The AC power supply (P11290-B21) supports a nominal input of 100-240Vac. Refer to the appendix for technical details.

Step 3: Configure ProLiant Server Blade (Min:1, Max: 2)

HPE ProLiant e910t 2U Configure to Order Blade Server

P27064-B21

Notes:

- Refer to the e910t quickspecs for blade configuration details:
<https://h20195.www2.hpe.com/v2/getdocument.aspx?docname=a00067735enw>
- Maximum of Two (2) e910t 2U blades Each blade operates independently.

Step 4: Configure Additional Options

Choose additional options for Factory Integration from sections below



Configuration Information

Rail Kit

HPE Edgeline EL8000T 2-post Rack Kit

P27067-B21

HPE Power Cords

HPE 48VDC 2.85m Power Cable	Q0H80A
HPE C15 US 125V 15Amp 2.5m Black Power Cord	Q7F42A
HPE C15 EU 250V 10Amp 2.5m Black Power Cord	Q7F45A
HPE C15 UK 250V 10Amp 2.5m Black Power Cord	Q7F46A
HPE C15 CN 250V 10Amp 2.5m Black Power Cord	Q7F53A
HPE C15 US 250V 10Amp 2.5m Black Jumper Cord	Q7F57A
HPE C15 EU 250V 10Amp 2.5m Black Jumper Cord	Q7F58A
HPE C15 US 250V 10Amp 0.76m Black Jumper Cord	Q7F59A
HPE C15 EU 250V 10Amp 0.76m Black Jumper Cord	Q7F60A
HPE C15 US 250V 10Amp 1m Black Jumper Cord	Q7F61A
HPE C15 EU 250V 10Amp 1m Black Jumper Cord	Q7F62A
HPE C15-C14 IN 250V 10Amp 2.5m Black Jumper Cord	R1C67A
HPE C15-C14 IN 250V 10Amp 1m Black Jumper Cord	R1C68A

HPE Support Services

Proactive Care

HPE 3 Year Proactive Care 24x7 Edgeline 8000t 2U Chassis Service

Foundation Care

HPE 3 Year Foundation Care 24x7 Edgeline 8000t 2U Chassis Service

Installation & Startup Services

HPE Installation Edgeline 8000t Chassis Service

HF8S4E

HPE Installation and Startup Edgeline Edgeline 8000t Service

U8JA4E

Notes: For a full listing of support services available for this server, please visit <https://ssc.hpe.com/>



Technical Specifications

Power Supply Specifications

Murata (MPS) D1U54P-W-1500-12-HCxTC

HPE Edgeline EL8000 1500W 264VAC Front Cabling Power Supply Kit	P11290-B21		
Input Voltage Range (Vrms)	100-240 Nominal (90-264 range)		
Frequency Range (Nominal) (Hz)	50-60 nominal (47-63 range)		
Nominal Input Voltage (Vrms)	90-100 (100)	110-120 (115)	200-240 (240)
Maximum Rated Output Wattage Safety (Watts)	1260	1500	1500
Nominal Input Current (Arms)	14.1	14.5	6.9
Maximum Rated Input Wattage Rated (Watts)	1394	1646	1636
Maximum Rated VA (Volt-Amp)	1410	1668	1656
Efficiency (%)	90.4	91.1	91.7
Power Factor	0.9886	0.9868	0.9879
Leakage Current (mA); max as per safety files	0.94mA; 264V; 60Hz		
Maximum Inrush Current (A peak)	<15Apk, 264Vac cold start		
Maximum Inrush Current duration (ms)	<2ms		
Maximum British Thermal Unit Rating (BTU-Hr)	4757	5651	5582

Murata (MPS) D1U54-D-1500-12-HCxC

HPE Edgeline EL8000 1500W - 48VDC Front Cabling Power Supply Kit	P11291-B21		
Input Voltage Range (VDC)	-40 to -72		
Frequency Range (Nominal) (Hz)	DC		
Nominal Input Voltage (VDC)	-40	-48	-72
Maximum Rated Output Wattage Rating (Watts)	1500	1500	1500
Nominal Input Current (A DC); 12V/133A; 3.3/6A	45.5	38.1	24.8
Maximum Input Wattage Rating (Watts)	1856	1828	1786
Maximum VA (Volt-Amp)	1856	1828	1786
Efficiency (%)	88.4	89.7	91.9
Power Factor	N/A		
Leakage Current (mA)	N/A		
Maximum Inrush Current (A peak); 72VDC; fullload	<20		
Maximum Inrush Current duration (ms)	<30		
Maximum British Thermal Unit Rating (BTU-Hr)	6333	6337	6094



Technical Specifications

Physical Dimensions

- **Chassis Dimensions (H x W x D)**
 - Height 3.5" (2U) (8.89 cm)
 - Width 19" (48.26 cm)
 - Depth 17" (43.2 cm)
- **Weight:** 25 lbs
- **Power**
 - Typical: Maximum: 3000W (with power supply redundancy)

System Inlet Temperature

- **Extended Operating**

Depending on hardware configuration, the supported system inlet range can be extended up to 55°C. Compliance to ASHRAE A3 and A4 standards is also available.

Notes: The approved extended temperature hardware configurations for this system are listed in the appendix.
- **Standard Operating**

10° to 35°C (50° to 95°F) at sea level with an altitude derating of 1.0°C per every 305 m (1.8°F per every 1000ft) above sea level to a maximum of 3050m (10,000ft), no direct sustained sunlight. Maximum rate of change is 20°C/hr (36°F/hr). The upper limit and rate of change may be limited by the type and number of options installed.

Notes: When configured with certain server models, a fan fault when operating above 30°C (86°F) may reduce system performance. Refer to the appendix for details.
- **Non-Operating**

-30° to 60°C (-22° to 140°F). Maximum rate of change is 20°C/hr (36°F/hr).

Relative Humidity

- **Operating**

Minimum to be the higher (more moisture) of -12°C (10.4°F) dew point or 8% relative humidity. Maximum to be the lower (less moisture) of 24°C (75.2°F) dew point or 90% relative humidity
- **Non-Operating**

5 to 95% relative humidity (Rh), 38.7°C (101.7°F) maximum wet bulb temperature, non-condensing.

Altitude

- **Operating**

3050 m (10,000 ft). This value may be limited by the type and number of options installed. Maximum allowable altitude change rate is 457 m/min (1500 ft/min).
- **Non-Operating**

9144 m (30,000 ft). Maximum allowable altitude change rate is 457 m/min (1500 ft/min)

Emissions Classification (EMC)

- **FCC Rating**

Class A
- **Normative Standards**

CISPR 22; EN55022; EN55024; FCC CFR 47, Pt 15; ICES-003; CNS13438; K22;K24; EN61000-3-2; EN 61000-3-3; EN 60950-1; IEC60950-1

Notes: Product conformance to cited product specifications is based on sample (type) testing, evaluation, or assessment. This product or family of products is eligible to bear the appropriate compliance logos and statements.



Technical Specifications

Hewlett Packard Enterprise Extended Ambient Operating Temperature Support

The American Society of Heating Refrigeration and Air-Conditioning Engineers set standards for building systems, energy efficiency, indoor air quality, refrigeration and sustainability. The ASHRAE A3 and A4 classes are the latest classes that have been defined in an effort to support the Fresh Air Data cooling initiative. Hewlett Packard Enterprise Extended Ambient Operating Support is defined below as comparable to an ASHRAE class. For selected system configurations the Hewlett Packard Enterprise Edgeline Extended Ambient Operating Support allows operation even beyond ASHRAE class.

Notes: Actual allowable system operating temperature will be determined by the options (I/O cards, drives etc.) selected. Details are provided in the Edgeline system configuration tables for the desired operating environment shown below.

The following table provides a summary of environmental ranges supported, with altitude de-ratings, by Hewlett Packard Enterprise ProLiant servers. Items in bold are ProLiant features that exceed the ASHRAE comparable class feature set.

Extended Ambient Operating Support Specification					
Ambient Operating	Dry bulb temp range (°C)	Relative humidity range (%RH)	Dew point limits (°C)	Maximum altitude	Altitude de-rating*
Standard Operating	10°C to 35°C (50°F to 95°F)	8% to 90%	-12°C (min) to 24°C (max)	3050 meters	1.8°C/305m above sea level
Extended Ambient 40°C Operating (ASHRAE Class A3 compliant)	5°C to 40°C (41°F to 104°F)	8% to 90%	-12°C (min) to 24°C (max)	3050 meters	1.0°C/175m above 900m
Extended Ambient 45°C Operating (ASHRAE Class A4 compliant)	5°C to 45°C (41°F to 113°F)	8% to 90%	-12°C (min) to 24°C (max)	3050 meters	1.0°C/125m above 900m
Extended Edgeline Ambient 55°C Operating	0°C to 55°C (32°F to 131°F)	8% to 90%	-12°C (min) to 24°C (max)	3050 meters	1.8°C/305m above sea level

Notes:

- *Altitude de-rating assumes no direct sustained sunlight
- The maximum rate of change for Inlet Ambient Temperature is 20°C/hr (36°F/hr). The upper limit and rate of change can be limited by the type and number of options selected.

Hewlett Packard Enterprise Operating Support				
Component	Support Status			
Type	Standard	Extended Ambient	Extended Ambient	Extended Edgeline Ambient
Operating Support	10°C to 35°C	40°C (ASHRAE Class A3 compliant)	45°C (ASHRAE Class A4 compliant)	55°C
Base System	Supported	Supported	Supported	Supported ¹
Fans	Supported with Redundancy	Supported with Redundancy	Supported with Redundancy ²	Supported with Redundancy ²
SATA M.2	Supported	Supported	Supported	Supported
NVMe M.2	Supported	Supported	Supported	Supported with exceptions ⁴
PCIe I/O Cards	Supported ³	Supported ³	Supported ³	Supported ³

Notes:

- ¹Near 55°C inlet ambient AND when the CPU is stressed at 100%.
- ²Upon fan failure the servers in the system may reduce performance
- ³Only HPE PCIe options cards were used in this testing
- ⁴The following SSDs may reduce performance when operating above 45°C ambient temp or fan failure:
 - o P05896-B21: HPE Edgeline 1.92TB NVMe x4 Lanes Mixed Use M.2 22110 3yr Wty Extended Temperature SSD
 - o P05900-B21: HPE Edgeline 3.84TB NVMe x4 Lanes Mixed Use M.2 22110 3yr Wty Extended Temperature SSD



Summary of Changes

Date	Version History	Action	Description of Change
01-Jun-2020	Version 1	New	New QuickSpecs



Copyright

Make the right purchase decision.
Contact our presales specialists.



Chat



Email



Call



Get updates



Hewlett Packard
Enterprise

© Copyright 2020 Hewlett Packard Enterprise Development LP. The information contained herein is subject to change without notice. The only warranties for Hewlett Packard Enterprise products and services are set forth in the express warranty statements accompanying such products and services. Nothing herein should be construed as constituting an additional warranty. Hewlett Packard Enterprise shall not be liable for technical or editorial errors or omissions contained herein.

a00073755enw - 16608 - WorldWide - V1 - 01-June-2020